

## Exam (1)

**Part (1) Objective questions (multiple choice) "Each question has one mark":-**

(1) In the opposite electric circuit, when the value of the resistance taken from  $R_V$  decreases, the reading of the voltmeter (V).....

- A Increases
- B Decreases
- C Remains unchanged
- D Becomes zero

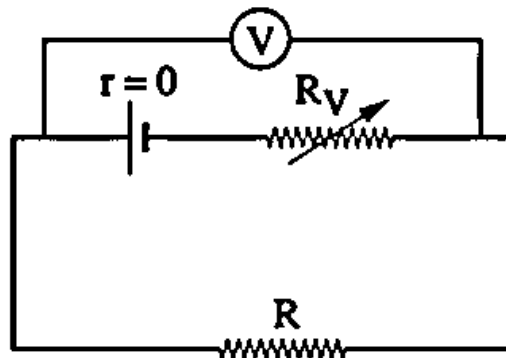

(2) Two wires of same material, if the diameter of the first is three times the diameter of the second, and the resistance of the second is four times the resistance of the first, so the length of the second wire is..... the length of the first one.

- A  $\frac{4}{3}$
- B  $\frac{4}{9}$
- C  $\frac{72}{2}$
- D  $\frac{36}{3}$

## Exam (1)

(3) Three identical resistors, each of value  $24 \Omega$ , are connected in different ways, hence the following choices represent the possible values of their equivalent resistance except.....

- A  $36 \Omega$
- B  $20 \Omega$
- C  $16 \Omega$
- D  $8 \Omega$

(4) In the opposite circuit, there is a resistance  $ab$  of  $12 \text{ k}\Omega$  where its terminals are connected to a potential difference of  $220 \text{ V}$ . If the part  $ac$  that represents the quarter of the resistance  $ab$  is connected to a voltmeter of resistance  $6 \text{ k}\Omega$ , So the voltmeter reading equals .....

- A  $36 \text{ V}$
- B  $32 \text{ V}$
- C  $42 \text{ V}$
- D  $40 \text{ V}$

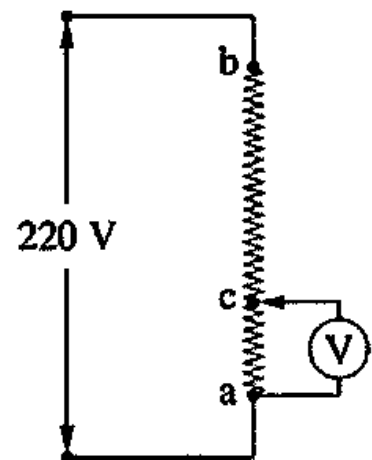

## Exam (1)

- (5) In the opposite figure, a straight wire is placed perpendicular to a uniform magnetic field of flux density  $B$  that is directed into the page. When an electric current of intensity  $I$  passes in the wire, the total magnetic flux density at point  $P$  becomes  $3B$ , so the net magnetic flux density at point  $Q$  is .....

- A zero
- B  $B$
- C  $2B$
- D  $3B$

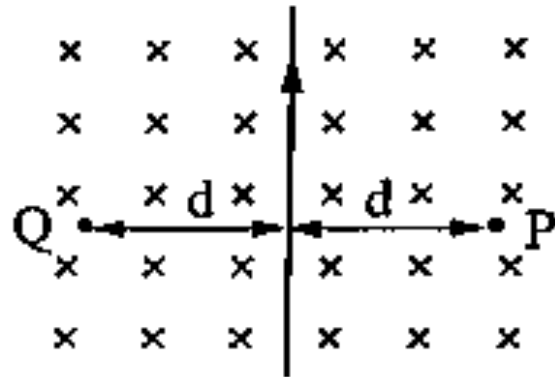

- (6) In the opposite figure a circular wire ring and a straight wire placed at the position  $x$  in the same plane of the ring and both carries electric current its intensity  $I$  so that the resultant magnetic flux density at the center of the ring  $c$  is  $B$  and when the wire is moved to position  $y$  the magnetic flux density at point  $c$  becomes .....

- A  $2B$
- B  $B$
- C  $0.73B$
- D  $1.38B$

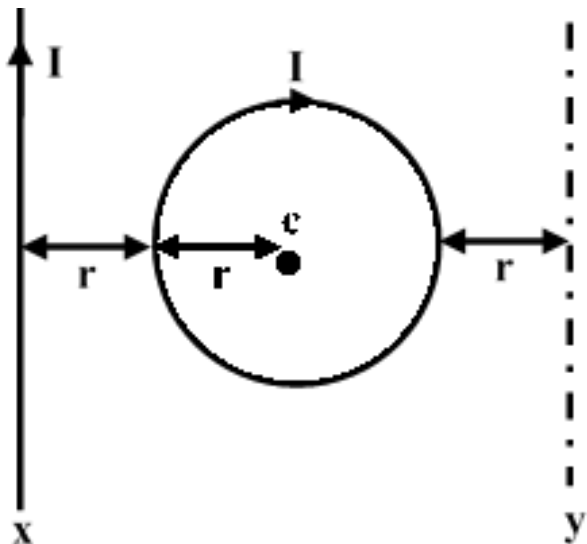

## Exam (1)

- (7) In the opposite figure, a solenoid carries an electric current that produce a magnetic flux of density  $2 \times 10^{-6} \text{ T}$  at the center of its axis at point p and a straight wire is placed perpendicular to the plane of the page above the solenoid. The wire carries an electric current that generates a magnetic flux of density  $4 \times 10^{-6} \text{ T}$  at point p, then the total magnetic flux density at point p is.....

- A  $2\sqrt{5} \times 10^{-6} \text{ T}$
- B  $6 \times 10^{-6} \text{ T}$
- C  $2 \times 10^{-6} \text{ T}$
- D  $4 \times 10^{-6} \text{ T}$

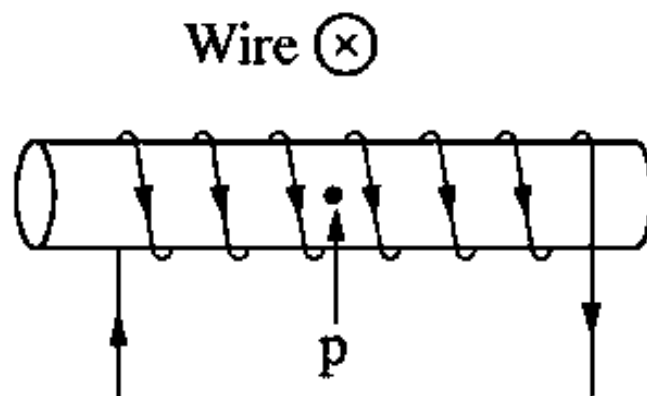

- (8) In the opposite figure, three parallel wires carry electric current as shown in the figure, then the net magnetic force which acts on one meter of the wire y is..... (Where:  $\mu = 4 \pi \times 10^{-7} \text{ Wb/A.m}$ )

- A  $3.42 \times 10^{-4} \text{ N/m}$
- B  $2.65 \times 10^{-5} \text{ N/m}$
- C  $4.67 \times 10^{-4} \text{ N/m}$
- D  $3.78 \times 10^{-5} \text{ N/m}$

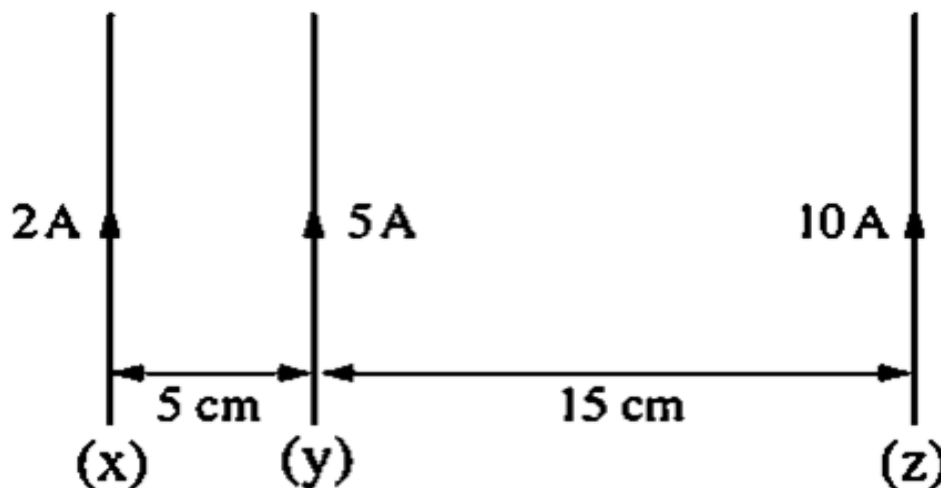

## Exam (1)

- (9) Which of the following adjustments can be done on a galvanometer device to increase its range for measuring electric current intensity than the other adjustments.....
- A Connecting a shunt resistance of value one fifth that of the galvanometer's resistance
  - B Connecting a shunt resistance of value one third that of the galvanometer's resistance
  - C Connecting a multiplier resistance of value double that of the galvanometer's resistance
  - D Connecting a shunt resistance of value half that of the galvanometer's resistance
- (10) A circular coil formed of one turn carries electric current intensity  $I$ , if the magnetic flux density at its center is  $B_1$  and then it is reshaped to another circular coil of  $N$  turns and carried the same current intensity, then the magnetic flux density at its center will be .....
- A  $NB_1$
  - B  $N^2B_1$
  - C  $2NB_1$
  - D  $2N^2B_1$

## Exam (1)

(11) The scale of a sensitive galvanometer consists of 20 divisions. If its pointer deflects to half its scale when a current of intensity 0.2mA passes in its coil, then each division of the scale indicates.....

- A 20 $\mu$ A
- B 10 $\mu$ A
- C 5 $\mu$ A
- D 2 $\mu$ A

(12) In the shown figure, avoiding the mutual induction between the two coils the magnet can move freely around its center of rotation between the two coils so at the moment of closing the switch (K) the electric potential of point (a) becomes .....

- A greater than that of (b).
- B less than that of (b).
- C equal to that of (b).
- D equal to zero.

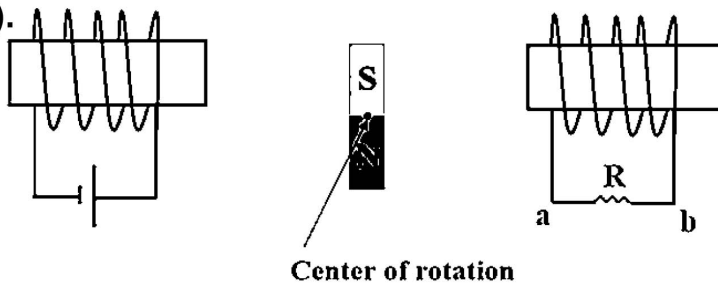

## Exam (1)

(13) In the shown figure when R decreases, the light of lamp.....

- A decreases momentarily
- B increases momentarily
- C remain as it is
- D switches off.

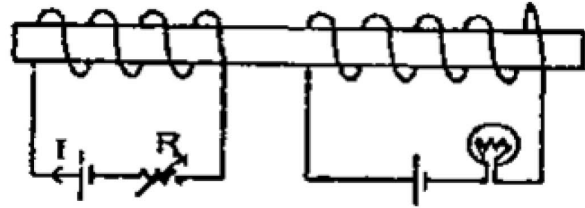

(14) In the standard resistors, it's coil are made of double wound wires.....

- A to reduce the resistance of the wire
- B to increase the resistance of the wire
- C to avoid self-induction
- D to vanishes the resistance in the wire

## Exam (1)

(15) A straight wire of length 20 cm moves at velocity 0.5 m/s in a direction that makes angle ( $\theta$ ) with the direction of a magnetic field of flux density 0.4 T, so an induced emf of 20 mV is generated between its terminals, hence the angle ( $\theta$ ) equals.....

- A  $60^\circ$
- B  $30^\circ$
- C  $45^\circ$
- D  $90^\circ$

(16) The opposite graph represents the relation between the maximum induced emf for an AC dynamo and the angular velocity for the rotation of its coil. If the number of turns of the coil is 100 turns and the magnetic flux density that acts on the coil is 0.1 T, then the area of the coil equals....

- A  $0.12 \text{ m}^2$
- B  $0.001 \text{ m}^2$
- C  $0.0012 \text{ m}^2$
- D  $0.06 \text{ m}^2$

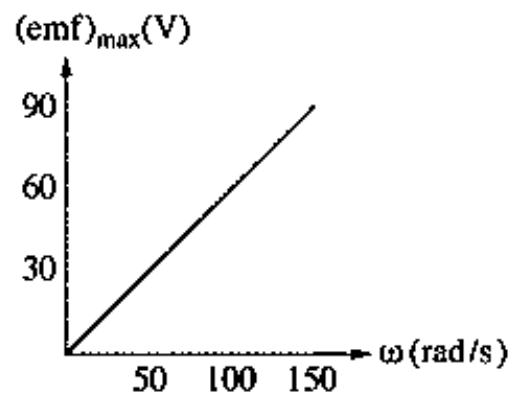

## Exam (1)

(17) During the rotation of the coil of the electric motor, the back induced electromotive force acts to .....

- A increase the electric current intensity.
- B change the electric current direction in the coil.
- C increase the speed of rotation of the coil.
- D stabilize the speed of rotation of the coil.

(18) The opposite figure represents a non-ideal transformer having two secondary coil that are working together at the same time.

If  $(P_W)_{S1} = 50 \text{ W}$ ,  $(P_W)_P = 100 \text{ W}$ , then .....

- A  $(P_W)_{S2} > 100 \text{ W}$
- B  $100 \text{ W} > (P_W)_{S2} > 50 \text{ W}$
- C  $(P_W)_{S2} = 50 \text{ W}$
- D  $(P_W)_{S2} < 50 \text{ W}$

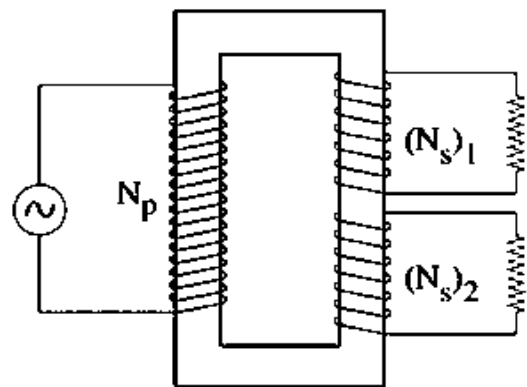

## Exam (1)

(19) Four students drew schematic diagrams for the hot wire ammeter scale, which student drawing is the correct scale for the hot wire ammeter?

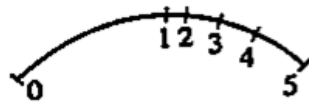

Student A

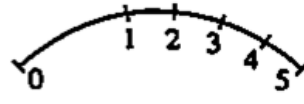

Student B

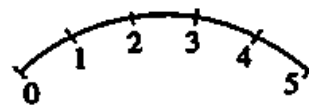

Student C

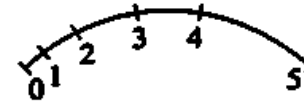

Student D

- A Student A
- B Student B
- C Student C
- D Student D

## Exam (1)

(20) The two figures (1) and (2) show parts of AC circuits. If the resonance frequency in figure (1) is 5 kHz, then the resonance frequency in figure (2) equals.....

- A 10 KHz
- B 5 KHz
- C 2.5 KHz
- D 40 KHz

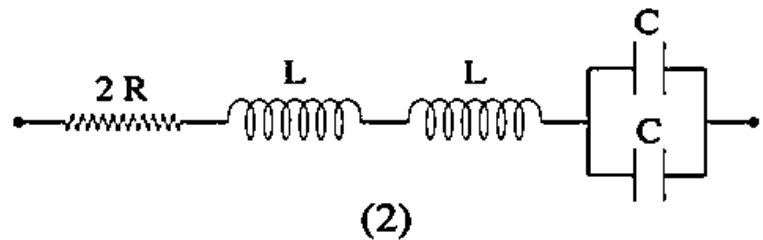
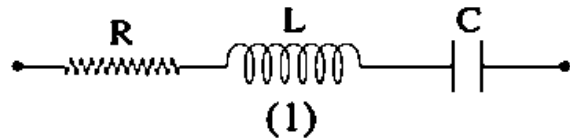

(21) In the opposite figure: If the effective value of the current passing in the circuit is 2A, then the capacitor capacitance ( $C$ ) is equal to ...

- A  $15 \mu\text{f}$
- B  $10 \mu\text{f}$
- C  $20 \mu\text{f}$
- D  $50 \mu\text{f}$

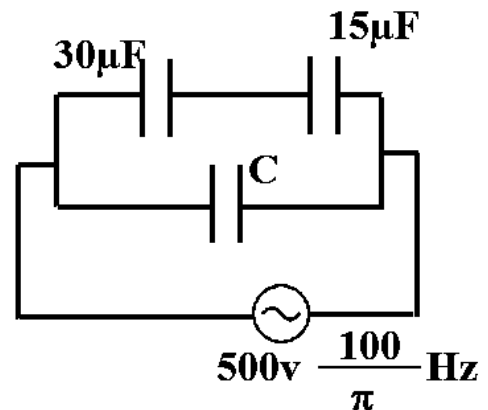

## Exam (1)

(22) Which of these figures represents resonance in R.L.C circuit?

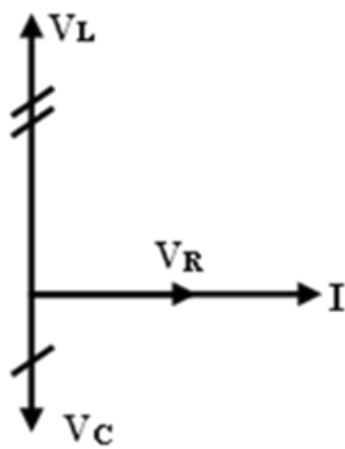

Figure (1)

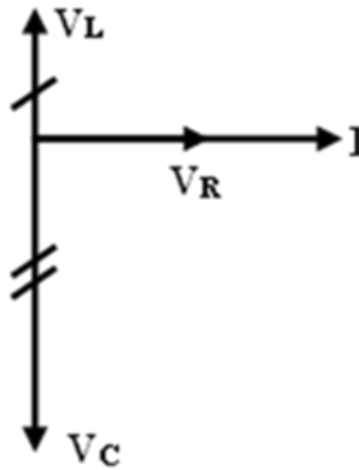

Figure (2)

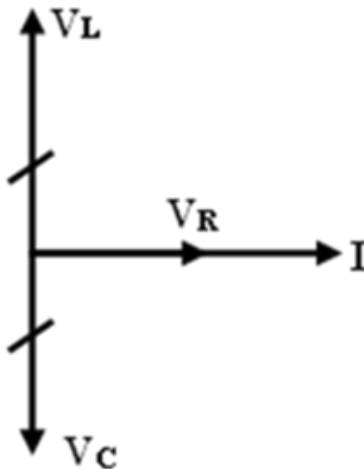

Figure (3)

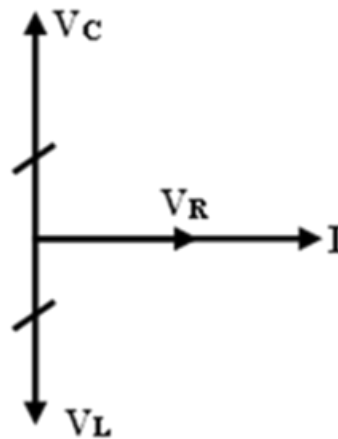

Figure (4)

- A Figure (1)
- B Figure (2)
- C Figure (3)
- D Figure (4)

## Exam (1)

(23) The opposite figure shows an incandescent electric bulb, so the ratio between the produced infra-red total energy to the produced visible light total energy through the same time is .....

- A greater than one
- B less than one
- C equal to one
- D not changed by the change of temperature



(24) In the electron microscope, when the potential difference between the cathode and the anode is increased from 25 kV to 100 kV, the wavelength associated with the motion of the electron beam .....

- A decreases to its quarter
- B decreases to its half
- C increases to its double
- D increases to its quadruple

## Exam (1)

(25) In Compton effect, when a photon X-ray collides with an electron at rest, then, .....

	The speed of the electron after collision	The equivalent mass of the photon after collision
<b>A</b>	<b>increases</b>	<b>increases</b>
<b>B</b>	<b>increases</b>	<b>decreases</b>
<b>C</b>	<b>decreases</b>	<b>increases</b>
<b>D</b>	<b>decreases</b>	<b>decreases</b>

(26) The opposite figure represents multiple probable transitions for the emission of a linear spectrum from the hydrogen atom, then.....

- A  $\lambda_A < \lambda_B$
- B  $\lambda_C > \lambda_D$
- C  $\lambda_B > \lambda_D$
- D  $\lambda_A > \lambda_C$

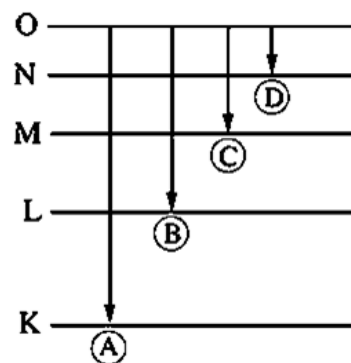

## Exam (1)

(27) An electron moves in energy level around the nucleus of hydrogen atom associated with a standing wave of wavelength  $\lambda$  as in the opposite figure, so the radius of the energy level (r) is ...

A  $\frac{4\lambda}{\pi}$

B  $\frac{2\lambda}{\pi}$

C  $\frac{\lambda}{\pi}$

D  $\frac{\lambda}{2\pi}$

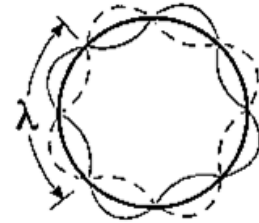

(28) A flash lamp is used as an energy source to excite the atom of active medium in ..... laser.

A Gas

B solid crystal

C liquid-dye

D semiconductor

## Exam (1)

(29) A laser ray of wavelength  $\lambda$  is used in holography where the phase difference between two rays of the reflected rays from the body was  $\frac{\pi}{2}$ , then the path difference between them is .....

A  $\frac{\lambda}{4}$

B  $\frac{\lambda}{2}$

C  $2\lambda$

D  $4\lambda$

## Exam (1)

(30) The figure shows a simple electric circuit that contains three switches (X, Y and Z) working as inputs of a logic circuit, while the lamp gives the output. The group of logic gates that is represented by this simple electric circuit is.....

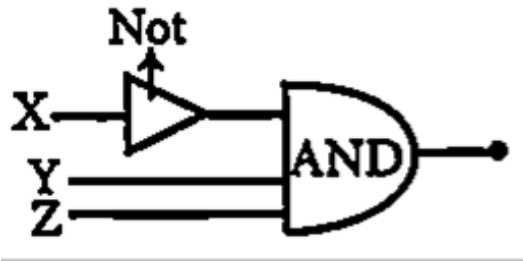
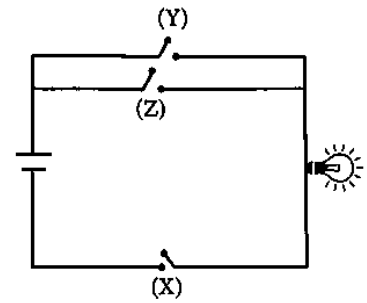

(a)

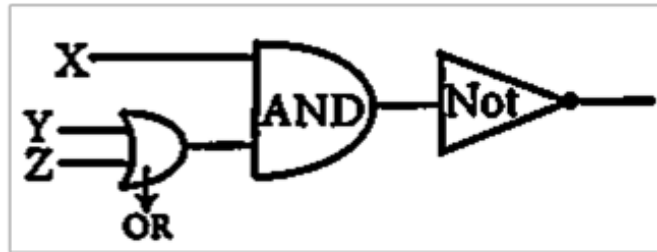

(b)

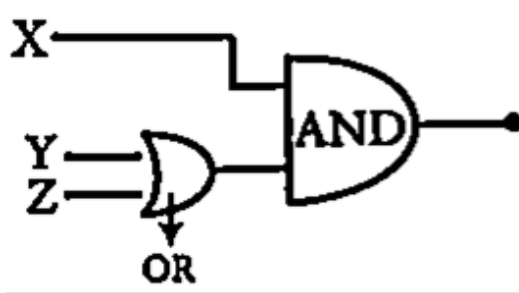

(c)

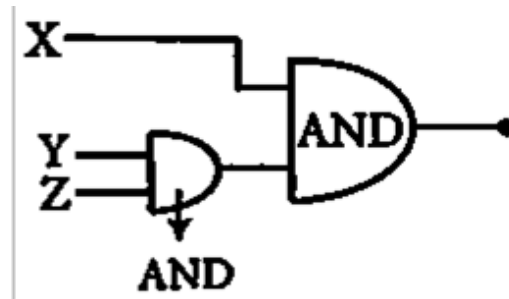

(d)

- A Group (a)
- B Group (b)
- c Group (c)
- D Group (d)

## Exam (1)

- (31) If the resistance of the diode is negligible in the case of forward biasing and infinite in the case of reverse biasing, then in the opposite circuit when the switch K is closed, the luminosity of the electric bulb.....

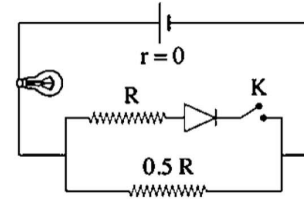

- A Remains unchanged  
B Vanishes  
C Increases  
D Decreases
- (32) If the concentrations of each of the free electrons and the holes in a doped semiconductor crystal are  $10^{14}\text{cm}^{-3}$  and  $10^8\text{cm}^{-3}$  respectively, so the concentration of the free electrons and the holes in the pure crystal before doping were ..... and ..... respectively.
- A  $10^{14}\text{cm}^{-3}$ ,  $10^8\text{cm}^{-3}$   
B  $10^8\text{cm}^{-3}$ ,  $10^{12}\text{cm}^{-3}$   
C  $10^8\text{cm}^{-3}$ ,  $10^{12}\text{cm}^{-3}$   
D  $10^{11}\text{cm}^{-3}$ ,  $10^{11}\text{cm}^{-3}$

## Exam (1)

***Part (2) Objective questions (multiple choice) "Each question has two mark":-***

(33) The opposite figure represents a part of an electric circuit that carries an electric current, then the value of  $V_B$  is.....

- A 25 V
- B 20 V
- C 30 V
- D 15 V

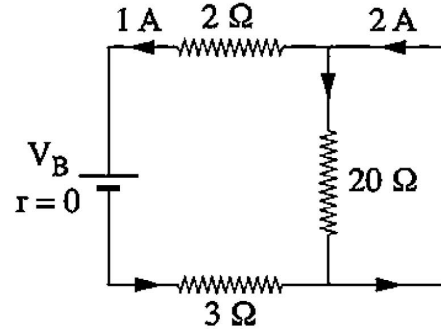

(34) The torque acting on a coil carrying current in a uniform magnetic field becomes maximum value when the direction of the magnetic dipole moment of the coil is ..... to the magnetic flux lines

- A Perpendicular to the magnetic flux lines.
- B Parallel to the magnetic flux lines.
- C Inclined by an angle  $30^\circ$  to the direction of magnetic field.
- D Inclined by an angle  $60^\circ$  to the direction of magnetic field.

## Exam (1)

- (35) A voltmeter, its resistance is  $100\ \Omega$  and the maximum voltage that can be measured by it is  $1\ \text{V}$ . The value of multiplier resistance that should be connected to increase the measured voltage by 10 times equals.....
- A  $0.9\ \text{k}\Omega$
  - B  $10\ \text{k}\Omega$
  - C  $1.1\ \text{k}\Omega$
  - D  $1\ \text{k}\Omega$
- (36) If a circular ring of radius  $5\text{cm}$  that carries an electric current of  $10\text{A}$  is bent such that each half ring becomes perpendicular to the other half, the resultant magnetic field intensity at the center will be ..... (Knowing that:  $\mu_{\text{air}} = 4\pi \times 10^{-7}\text{Wb/A.m}$ )
- A  $2.2 \times 10^{-5}\text{T}$
  - B  $4.5 \times 10^{-5}\text{T}$
  - C  $13.4 \times 10^{-5}\text{T}$
  - D  $8.9 \times 10^{-5}\text{T}$

## Exam (1)

(37) The opposite figure represents two adjacent solenoids P, Q and the opposite graph represents the relation between the current intensity ( $I$ ) in coil P and the time ( $t$ ), then the graph that represents the induced emf in coil Q versus time is.....

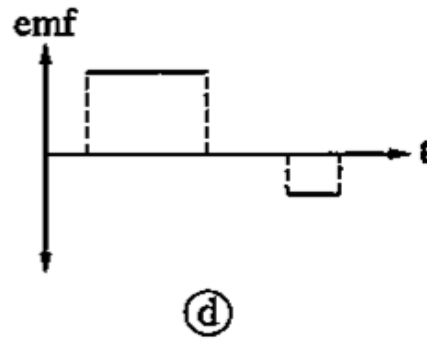
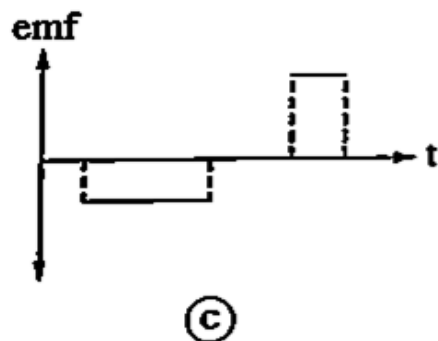
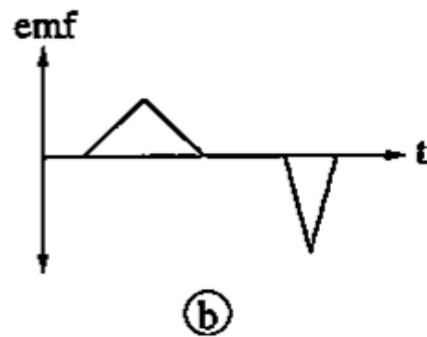
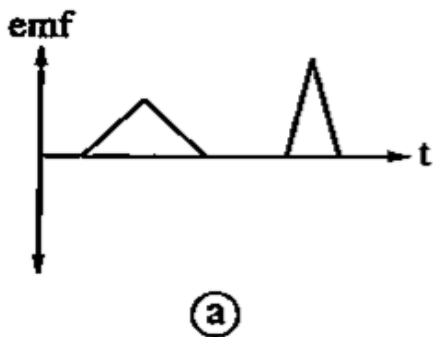
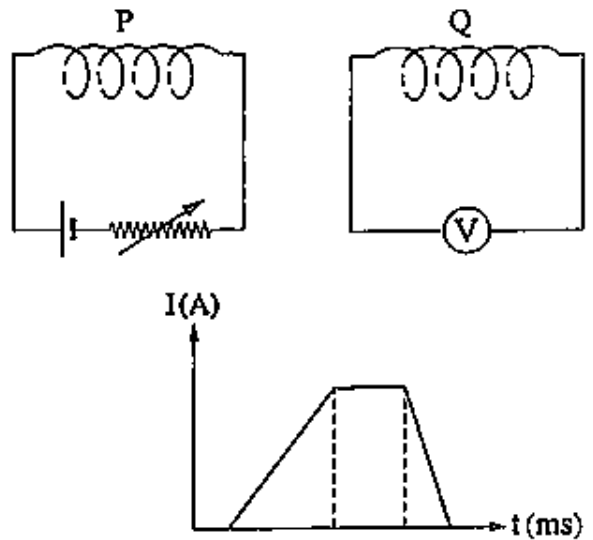

- A Graph (a)
- B Graph (b)
- c Graph (c)
- D Graph (d)

## Exam (1)

(38) two coils (x) and (y), the cross-section area of coil (x) twice the cross-section area of (y) put in the magnetic field. Which the magnetic flux density (B). two coils placed perpendicular on the direction of magnetic flux lines. When reverse the direction of the magnetic field through time (2ms). The ratio =  $\frac{\text{emf}_{\text{avrag}}(\text{x})}{\text{emf}_{\text{avrag}}(\text{y})} = \frac{3}{1}$ , so the

ratio  $\frac{\text{no.of turns (x)}}{\text{no.of turns (y)}} = \dots\dots\dots$

A  $\frac{3}{1}$

B  $\frac{3}{2}$

C  $\frac{1}{3}$

D  $\frac{2}{3}$

(39) The graph represents the relationship between the induced electromotive force (emf) in a dynamo coil and time during a half-cycle. The average electromotive force generated in the dynamo coil during the time period from zero to  $t = \frac{1}{75}$  sec .....volts

( $\pi = 3.14$ )

A 47.77

B 63.69

C 21.23

D 86.603

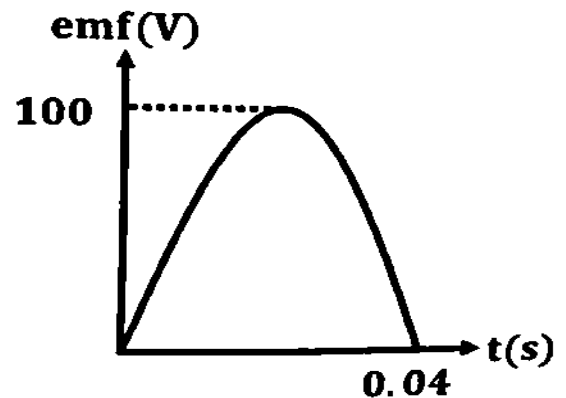

## Exam (1)

(40) The opposite figure represents a series RLC circuit, so the current intensity that passes through the circuit equals.....

- A 4 A
- B 8 A
- C 2 A
- D 6A

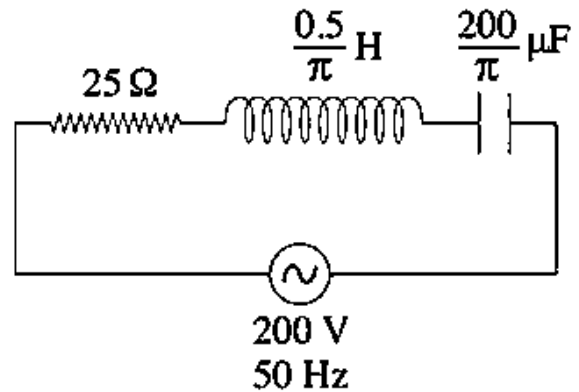

(41) The graph represents the relation between maximum kinetic energy for the emitted electrons from the surfaces of 4 different metals (A, B, C and D) and the frequency of the light falling on them. Which frequency causes electrons to get emitted from metal (A and B) but does not cause electrons emission from metals (C, D)?

- A  $\nu_3$
- B  $\nu_5$
- C  $\nu_2$
- D  $\nu_4$

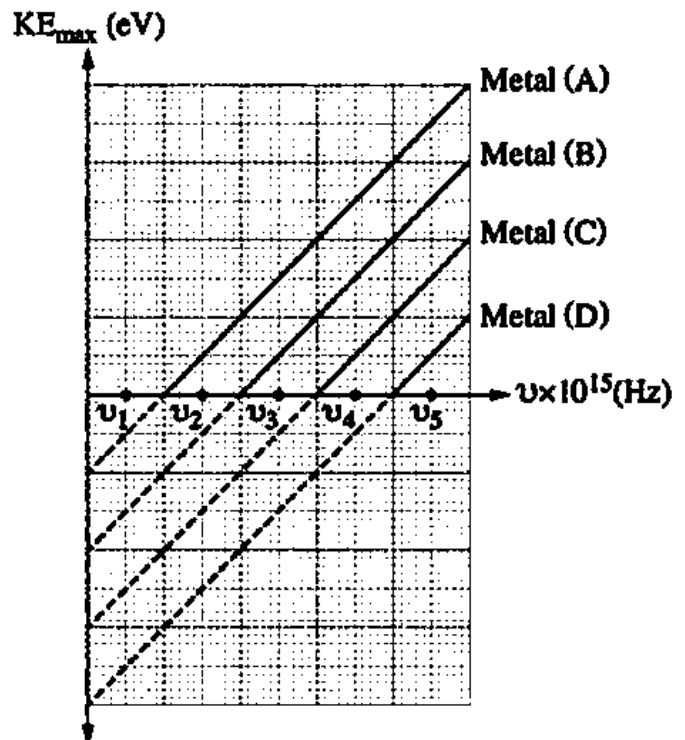

## Exam (1)

- (42) The opposite figure shows the relation between the X-rays intensity and its wavelength ( $\lambda$ ) for two Coolidge tubes which have targets of two different materials their atomic numbers  $Z_1$  and  $Z_2$  and operate on two different voltages  $V_1$  and  $V_2$  respectively.

Thus .....

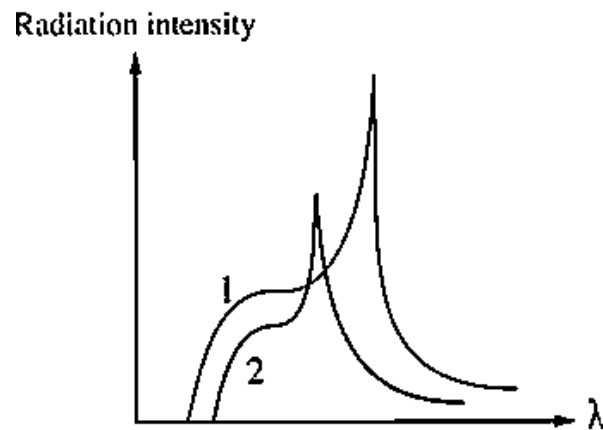

	Relation between $V_1, V_2$	Relation between $Z_1, Z_2$
<b>A</b>	$V_1 > V_2$	$Z_1 > Z_2$
<b>B</b>	$V_1 > V_2$	$Z_1 < Z_2$
<b>C</b>	$V_1 < V_2$	$Z_1 = Z_2$
<b>D</b>	$V_1 < V_2$	$Z_1 < Z_2$

## Exam (1)

- (43) The schematic diagram represents the (He-Ne) laser, so most of neon (Ne) atoms can be excited by .....

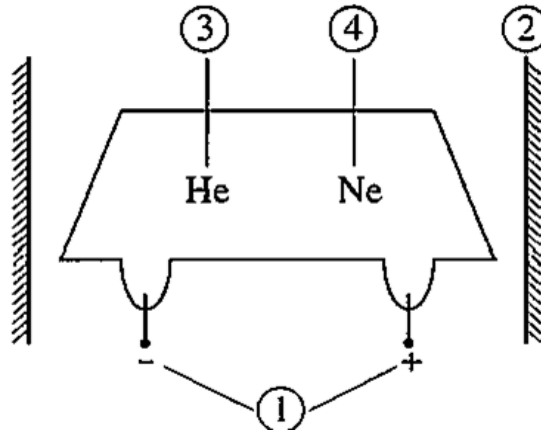

- A colliding with component (2)
  - B colliding with excited atoms of component (3)
  - C colliding with unexcited atoms of component (3)
  - D gaining energy from component (1)
- (44) In the npn transistor circuit, the resistance connected to its collector  $R_C = 50 \text{ k}\Omega$ , if its current gain  $\beta_e = 30$ , from the data on the figure the intensity of the base current ( $I_B$ ) = .....

- A  $3 \times 10^{-6} \text{ A}$
- B  $9.3 \times 10^{-5} \text{ A}$
- C  $9 \times 10^{-5} \text{ A}$
- D  $8.7 \times 10^{-6} \text{ A}$

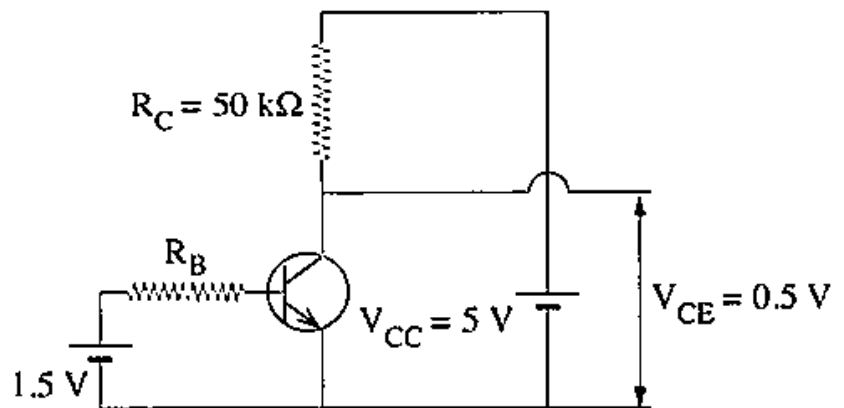

## Exam (1)

### Part (3) Essay questions "Each question has two mark":-

(45) An ohmmeter consists of an ammeter, a standard resistance and a 6V battery. It shows a full-scale deflection when a current of 1 mA flows through it

(i) Calculate the total resistance of the ohmmeter.

(ii) Calculate the external resistance that makes the pointer deflect to half its current scale.

(46) The opposite figure shows an ideal electric transformer that is connected between an AC source and a bulb then:

(i) What is the type of this transformer?

(ii) Calculate the ratio between  $\left(\frac{V_s}{V_p}\right)$ .

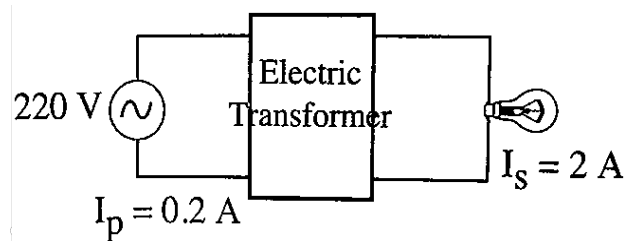

## Exam (2)

**Part (1) Objective questions (multiple choice) "Each question has one mark":-**

(1) In the opposite circuit, the ratio of  $\frac{V_1}{V_2} = \dots\dots$

- A  $\frac{V_B + Ir}{IR}$
- B  $\frac{IR}{V_B + V_2}$
- C  $\frac{IR - Ir}{V_2 - V_B}$
- D  $\frac{V_B - Ir}{IR}$

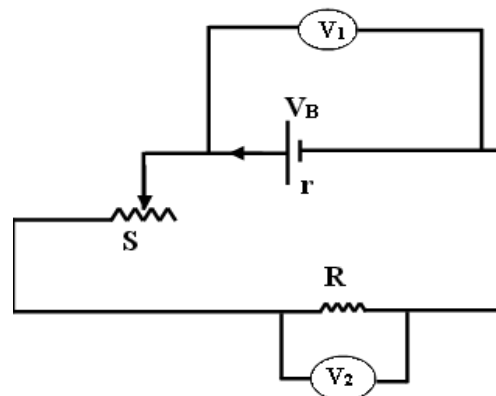

(2) The opposite diagram represents a closed electric circuit, so mark all the figures that represent the component X which make the pointer of the voltmeter deflect to 4 V?

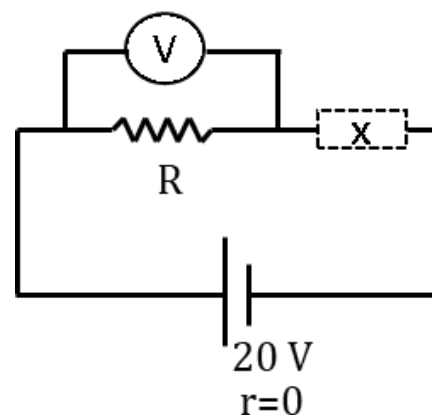
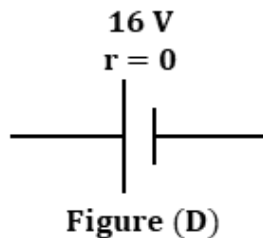
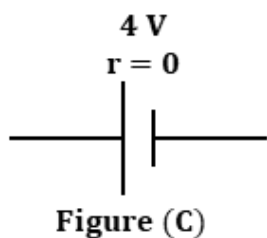
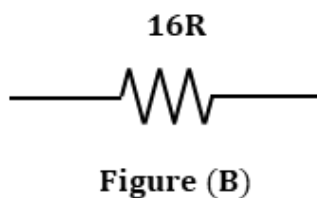
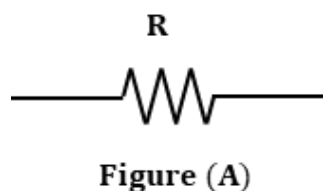

- A Figure (A)
- B Figure (B)
- C Figure (C)
- D Figure (D)

## Exam (2)

(3) The opposite circuit, the ratio  $\left(\frac{R_1}{R_2}\right)$  is.....

- A  $\frac{3}{2}$
- B  $\frac{3}{1}$
- C  $\frac{4}{1}$
- D  $\frac{4}{3}$

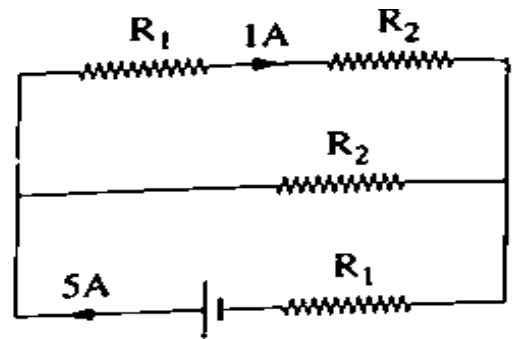

(4) In the opposite figure, when the switch (k) is closed, so the reading of the ammeter becomes.....

- A 0.5 A
- B 1.5 A
- C 2 A
- D 0.75 A

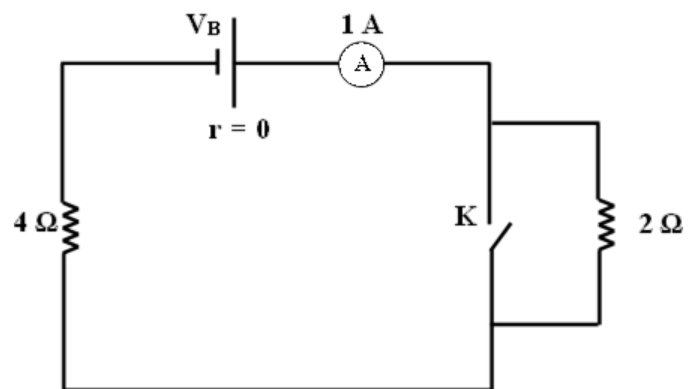

## Exam (2)

(5) A current carrying coil is free to move in a magnetic field of flux density 0.2 T, So if the ratio between the torque acting on the coil at a certain instant and its magnetic dipole moment  $\frac{3}{20}$  N/A.m, then the angle between the plane of the coil and the magnetic flux lines equals.....

- A  $41.41^\circ$
- B  $48.59^\circ$
- C  $32.46^\circ$
- D  $33.55^\circ$

(6) In the opposite figure, a metallic ring of center x is connected to an electric source via two points (a, b) as shown in the opposite figure, so that an electric current passes through the ring, hence the magnetic flux density at the center of the ring equals....

- A  $\frac{3\mu}{8r}$
- B  $\frac{6\mu}{8r}$
- C  $\frac{4\mu}{8r}$
- D 0

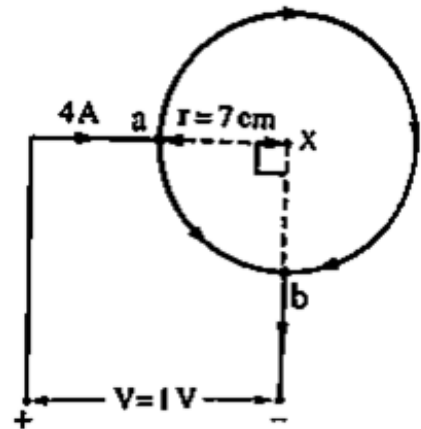

## Exam (2)

- (7) In the opposite figure, a straight wire (y) is perpendicular to the plane of the page at a distance 2 cm from the axis of a solenoid that consists of 50 turns/m and carries a current of intensity 1.4 A , so for the resultant of the magnetic flux density at the center of the axis of the solenoid (point z) to be vanished.....

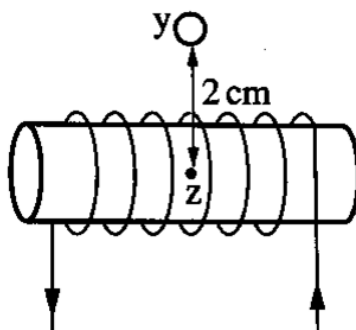

	The direction of the current in the wire has to be	The intensity of the current in the wire has to be
A	Perpendicular into of the page	2.2 A
B	Perpendicular into the page	6.6 A
C	Perpendicular out of the page	8.8 A
D	Perpendicular out of the page	4.4 A

## Exam (2)

- (8) The opposite figure represents a straight wire PQ which is free to move. If the wire is in the plane of the page and it carries an electric current of intensity  $I$  where two magnetic fields are acting on its terminals, then which of the following choices shows the directions of motion of the terminals of the wire?

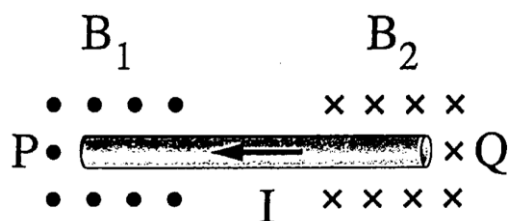

	The direction of motion of terminal P	The direction of motion of terminal Q
A	Perpendicular out of the page	Perpendicular into the page
B	Perpendicular into the page	Perpendicular out of the page
C	In the plane of the page upwards	In the plane of the page downwards
D	In the plane of the page downwards	In the plane of the page upwards

## Exam (2)

(9) If the pointer of the galvanometer deflects by an angle of  $30^\circ$ , when a current of  $300\mu\text{A}$  passes through it, then the galvanometer sensitivity equals.....

A  $\frac{2}{3}$  deg/ $\mu\text{A}$

B 0.1 deg/ $\mu\text{A}$

C 0.15 deg/ $\mu\text{A}$

D  $\frac{1}{3}$  deg/ $\mu\text{A}$

(10) Two parallel long wires (X) and (Y) the normal distance between them is 0.5 m , the two wires carrying currents pass in the same direction , the value of the current in wire X is (I) and that of wire Y is (3I), so that the position of the neutral point is at a distance ...

A 0.125 m from wire Y

B 0.25 m from wire Y

C 0.125 m from wire X

D 0.625 m from wire X

## Exam (2)

- (11) The opposite figure represents a rectangular coil (POQR) of number of turns  $N$ . The coil carries an electric current of intensity  $I$  while being placed in a uniform magnetic field of flux density  $B$  such that the plane of the coil is parallel to the magnetic flux lines. Which of the following graphs represents the relation between the magnetic dipole moment  $|\vec{m}_d|$  for the coil when it rotates  $90^\circ$  from that position versus the rotation angle ( $\theta$ )?

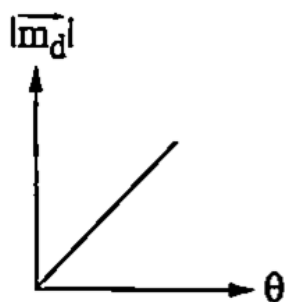
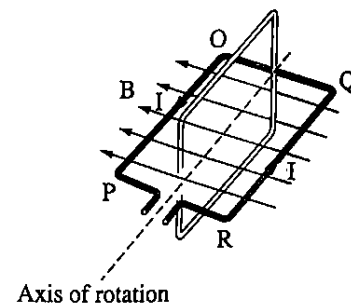

(a)

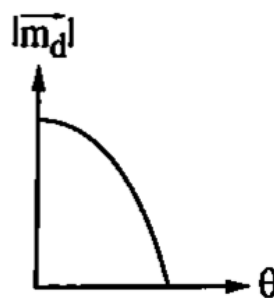

(b)

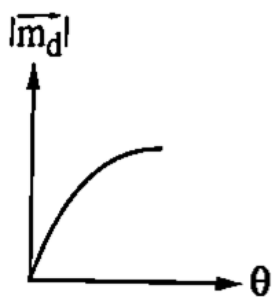

(c)

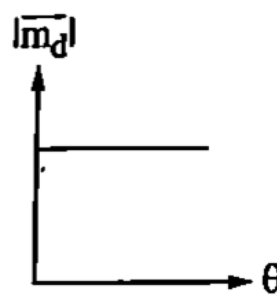

(d)

- A Figure (a)
- B Figure (b)
- c Figure (c)
- D Figure (d)

## Exam (2)

- (12) The opposite figure shows a rectangular coil that moves in the plane of the page to enter a uniform magnetic field which is perpendicular to the plane of the coil and directed into the page then exits from it. So, the direction of the induced current in the coil is.....

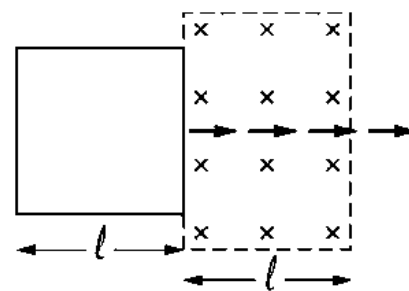

- A In the anti-clockwise direction then in the clockwise direction  
B In the clockwise direction then in the anti-clockwise direction  
C Always in the clockwise direction  
D Always in the anti-clockwise direction
- (13) The graph represents the relation between the induced electromotive force (emf) in the secondary coil and the rate of change of the electric current intensity in the adjacent primary coil  $\left(\frac{\Delta I}{\Delta t}\right)$ , so the mutual inductance between the two coils equals.....

- A 0.05 mH  
B 50 mH  
C 0.04 mH  
D 40 mH

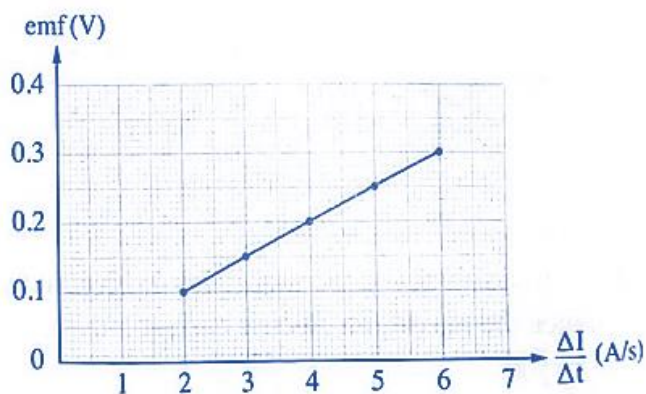

## Exam (2)

(14) Induction furnaces is application on.....

- A self- induction
- B mutual induction
- C eddy current
- D magnetic torque

(15) In the opposite figure: If the wire moved perpendicular to the magnetic flux lines in the shown direction, then the potential of point A ..... the potential of point B.

- A greater than
- B less than
- C equals
- D different

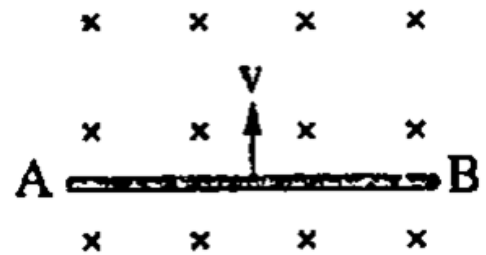

## Exam (2)

(16) rectangular coil of dimensions  $0.2\text{m} \times 0.4\text{m}$  and a number of turns 100 turns rotates at a constant angular speed of 500 revolutions per minute in a uniform field of density  $0.1\text{T}$  and the axis of rotation in the plane of the coil is perpendicular to the field, the maximum induced electromotive force generated in the coil approximately equal to .....

- A 32 V
- B 82 V
- C 66 V
- D 42 V

(17) The opposite figure shows the structure of a motor, so the components on which the direction of the acting torque on the coil depends are.....

- A Components (1), (2)
- B Components (1), (4)
- C Components (2), (4)
- D Components (3), (5)

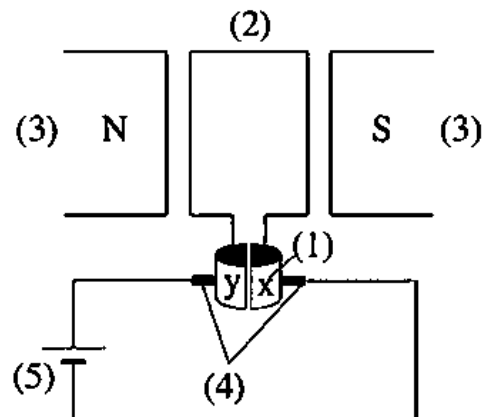

## Exam (2)

- (18) The number of turns of the coil in an ideal electric transformer are 400 turns and 200 turns, so if it is connected to an AC source of electromotive force 50 V, then the maximum electromotive force that can be obtained is.....
- A 60 V
  - B 100 V
  - C 80 V
  - D 90 V
- (19) In the hot wire ammeter, the wire is mounted on a metal plate of the same expansion coefficient, this is to.....
- A increase the expansion of the wire
  - B return the pointer back quickly to zero position as current is turned off
  - C avoid the zero error
  - D decrease the efficiency of the device

## Exam (2)

(20) An RLC circuit contains a capacitor of capacitance  $(\frac{1}{\pi} \mu\text{F})$ , a resistor of  $15\Omega$  and an induction coil of self-inductance  $(\frac{1}{\pi} \text{H})$ , then the resonance frequency of this circuit is.....

- A 250Hz
- B 400Hz
- C 500Hz
- D 625Hz

## Exam (2)

- (21) The coefficient of self-induction of three inductors of negligible ohmic resistances are  $L_1 = L$ ,  $L_2 = 2L$ ,  $L_3 = 3L$  respectively. If the three inductors are connected together in a certain way to an AC source of frequency  $\frac{500}{11}$  Hz, their equivalent reactance becomes  $200\pi L$  in ohms, so which of the following choices represents the correct way of connection of the three inductors?

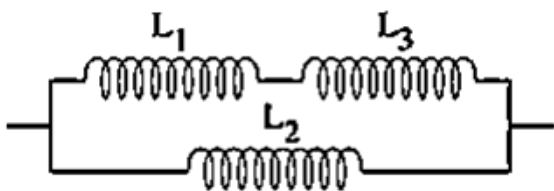

Figure (1)

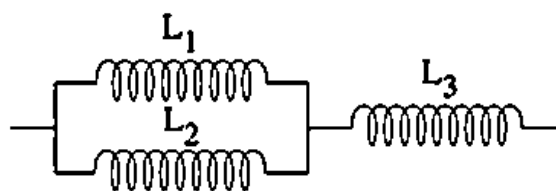

Figure (2)

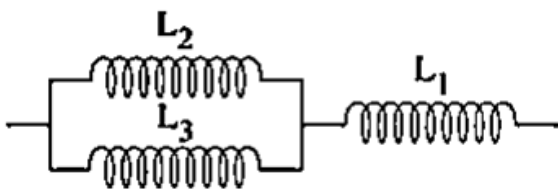

Figure (3)

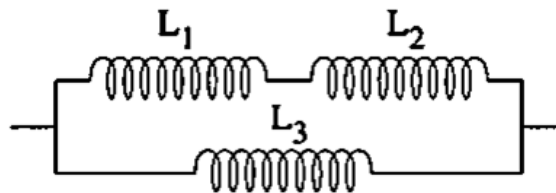

Figure (4)

- A Figure (1)
- B Figure (2)
- C Figure (3)
- D Figure (4)

## Exam (2)

(22) If the vector of voltage ( $V_R$ ), and ( $V$ ), in the circuit containing ( $R$ ) and ( $C$ ) connected to A.C. source, then .....

A  $\frac{V_R}{V} = \frac{\sqrt{3}}{3}$

B  $\frac{R}{X_C} = \frac{\sqrt{3}}{3}$

C  $\frac{Z}{R} = \frac{2\sqrt{3}}{3}$

D  $\frac{X_C}{R} = \frac{2\sqrt{3}}{3}$

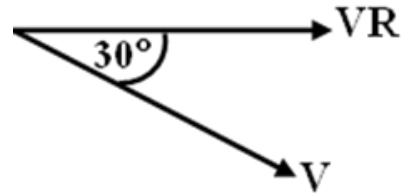

(23) Night vision devices depend on receiving what the bodies emit from .....

A visible radiation

B UV radiation

C thermal radiation

D X-rays

## Exam (2)

(24) In Compton effect, when a photon of  $\gamma$ -ray collides with an electron that is at rest, .....

	The mass of the electron after collision	The wavelength of the scattered photon
<b>A</b>	remains constant	decreases
<b>B</b>	decreases	decreases
<b>C</b>	remains constant	increases
<b>D</b>	increases	decreases

## Exam (2)

(25) The opposite figure shows two different surfaces (x, y) of critical frequencies  $\frac{1}{3}\nu$ ,  $\frac{1}{2}\nu$  respectively.

a light of the same frequency and intensity has fallen on both surfaces. Which of the following

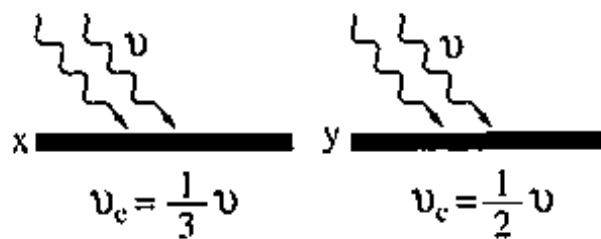

graphs represents the ratios of the kinetic energies of the electrons that emitted from the two surfaces?

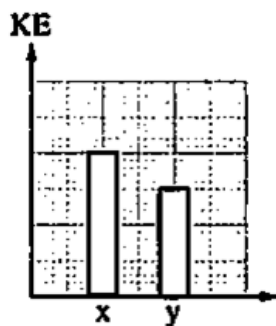

Figure (1)

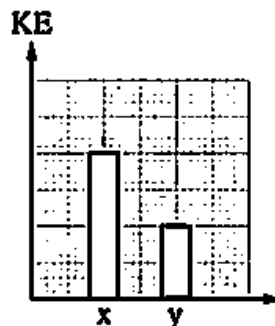

Figure (2)

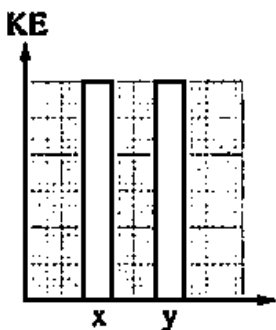

Figure (3)

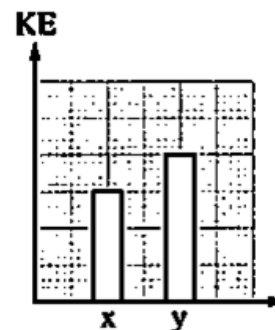

Figure (4)

- A Figure (1)
- B Figure (2)
- C Figure (3)
- D Figure (4)

## Exam (2)

(26) In the hydrogen atom, if  $\nu_1$  is the minimum frequency in Paasschen series and  $\nu_2$  is the minimum frequency in Balmer series, then the ratio  $(\frac{\nu_1}{\nu_2})$  is .....

- A  $\frac{7}{20}$
- B  $\frac{4}{3}$
- C  $\frac{20}{7}$
- D  $\frac{5}{2}$

(27) The opposite figure represents the standing wave that is associated with the motion of an electron in the hydrogen atom in one of the energy levels. If the wavelength of this wave is  $9.98 \times 10^{-10}$  m, then the radius of the energy level in which the electron is moving is.....

- A **5.24 Å**
- B **4.76 Å**
- C **2.42 Å**
- D **3.65 Å**

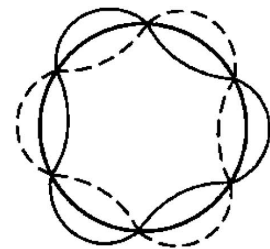

## Exam (2)

(28) The opposite graph represents the relation between the amplitude (A) with time (t) of two waves (a) and (b). Find the ratio between their intensities  $\frac{I_a}{I_b}$  .....

- A  $\frac{1}{2}$
- B  $\frac{1}{4}$
- C  $\frac{2}{1}$
- D  $\frac{4}{1}$

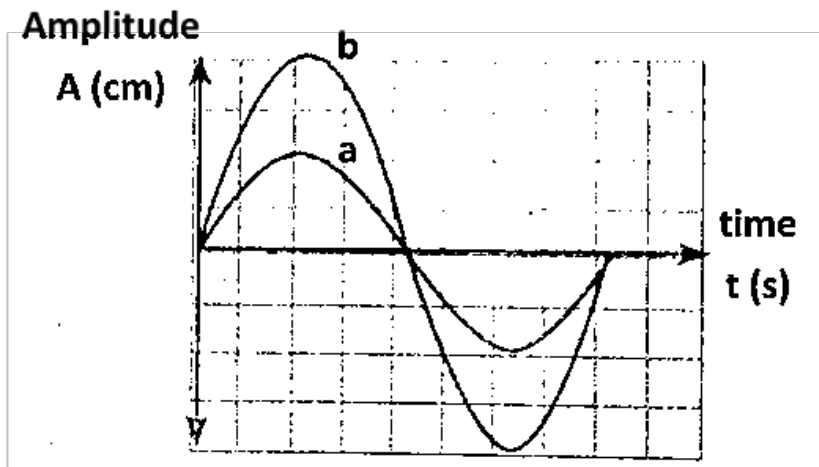

(29) The common property between laser photons and X-ray photon is that they.....

- A have the same speed in space
- B have the same energy in space
- C are coherent
- D are monochromatic

## Exam (2)

(30) Form the given truth table:

A	B	OUT
0	0	0
0	1	1
1	0	1
1	1	0

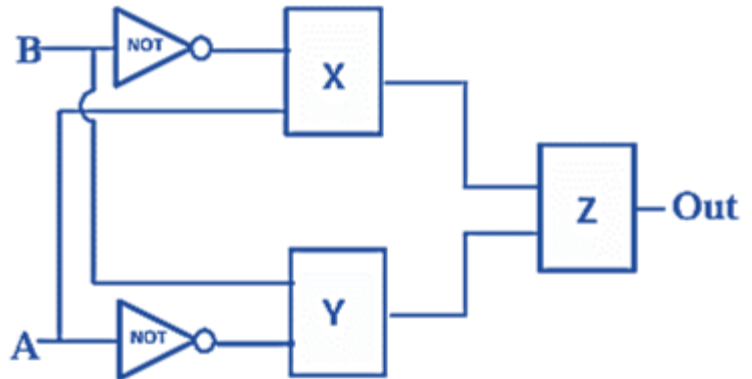

then the types of the gates (X, Y, Z):

	X	Y	Z
A	AND	AND	OR
B	OR	NOT	AND
C	NOT	OR	OR
D	OR	OR	AND

(31) The opposite circuit, the lamp glows when the switch S becomes in position.....

- A 3
- B 1
- C 1 or 3
- D 2

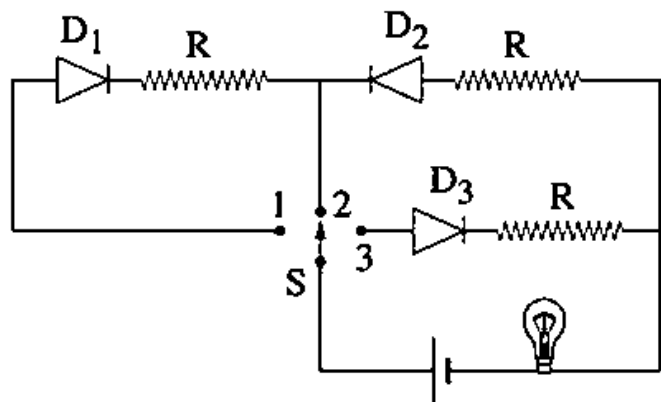

## Exam (2)

- (32) Which of the following choices correctly represents what happens to the reading of the ammeter when the shown element is made of copper and when made of germanium separately?

	Made of Copper	Made of Germanium
<b>A</b>	Remains the same	Increases
<b>B</b>	Increases	Remains the same
<b>C</b>	Decreases	Increases
<b>D</b>	Increases	Increases

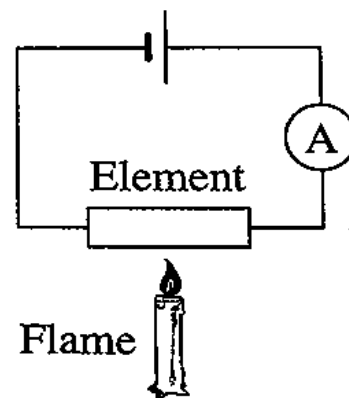

**Part (2) Objective questions (multiple choice) "Each question has two mark":-**

- (33) The opposite figure represents a part of an electric circuit, then the value of  $V_B$  equal.....

- A  $2 IR$
- B  $3 IR$
- C  $4 IR$
- D  $IR$

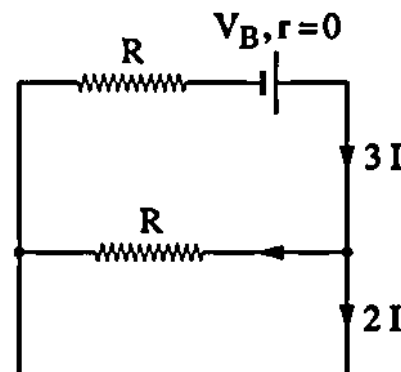

## Exam (2)

- (34) A battery of emf 14 V, whose internal resistance is negligible, is connected to a circular coil of radius 10 cm. If the coil is made of a wire whose material's resistivity is  $7 \times 10^{-7} \Omega \cdot \text{m}$  and its radius is 1 mm, the torque affecting the coil when its plane is positioned parallel to a magnetic field of flux density 0.5 T equals .....

(Take:  $\pi = 3.14$ )

- A 0.53 N.m  
B 0.61 N.m  
C 0.93 N.m  
D 1.57 N.m
- (35) Ohmmeter has resistance (R) passing through it current of intensity (I). When the ohmmeter is connected with external resistance of  $6000 \Omega$  the intensity of the current decreases to  $(\frac{1}{3} I)$  so the resistance of ohmmeter is .....
- A  $2000 \Omega$   
B  $3000 \Omega$   
C  $6000 \Omega$   
D  $9000 \Omega$

## Exam (2)

(36) A coil that has a one turn of wire is carrying an electric current of intensity  $I$ , then the same wire of that coil is recoiled as a circular coil of 4 turns while the intensity of the passing electric current becomes  $\frac{I}{2}$ , so the ratio between the magnetic flux density at the center of the coil in the first case to that in the second case equals.....

A  $\frac{4}{9}$

B  $\frac{9}{4}$

C  $\frac{1}{8}$

D  $\frac{8}{1}$

## Exam (2)

- (37) The opposite graph shows the relation between the electric current intensity ( $I$ ) and the time ( $t$ ) in an inductor. Which of the following graphs represents the relation between the induced emf in the inductor and the time ( $t$ )?

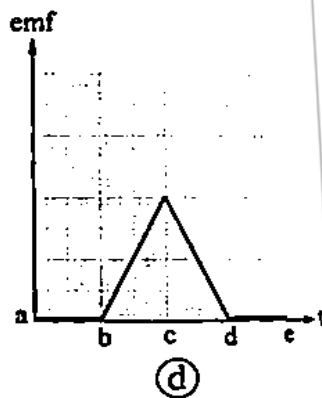
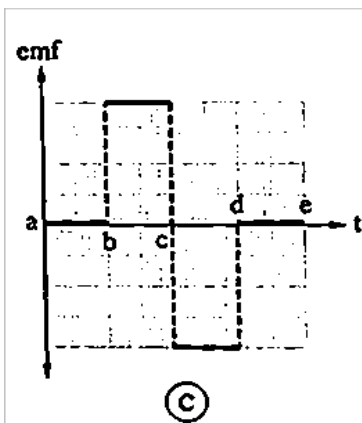
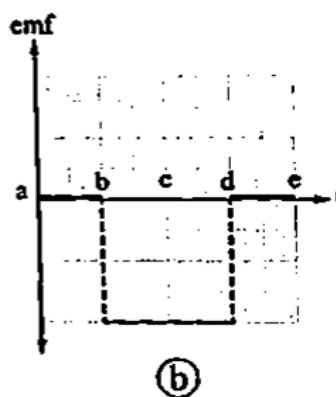
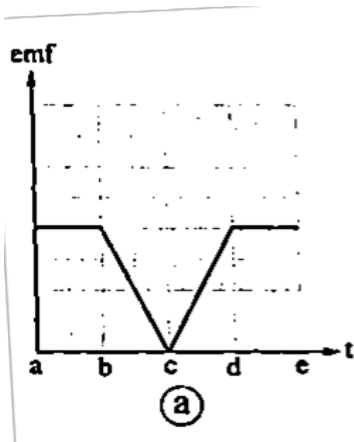
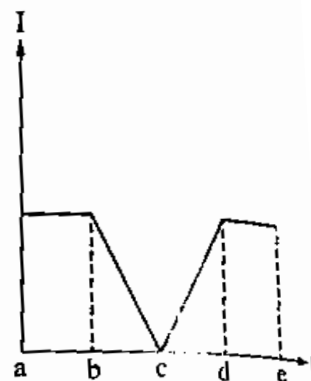

- A Graph (a)
- B Graph (b)
- C Graph (c)
- D Graph (d)

## Exam (2)

(38) A coil is placed in a uniform magnetic field so that the plane of the coil is normal to the direction of magnetic field, so the ratio

between  $\frac{\text{the average induced e.m.f when the coil is rotated } \frac{1}{4} \text{ cycle in time } t}{\text{the average induced e.m.f when the coil is rotated } \frac{1}{2} \text{ cycle in time } t} = \dots\dots\dots$

- A 0.5
- B 1
- C 0.25
- D 0.75

(39) A rectangular coil that rotates around its axis in a magnetic field its density 1 Tesla and the area of the coil = 70 cm<sup>2</sup> and it rotates 300 revolutions every  $\frac{1}{2}$  minute and the number of turns of coil is 100 turns, the time period starting from the vertical position of the coil until it reaches to +22 volts for the first time is equal to..... sec.

- A  $\frac{1}{600}$
- B  $\frac{3}{600}$
- C  $\frac{5}{600}$
- D  $\frac{7}{600}$

## Exam (2)

(40) In the opposite circuit, if  $(X_L)_1 = (X_L)_2 = (X_C)_1 = (X_C)_2 = R$ , then the circuit has.....

- A Inductive properties
- B Capacitive properties
- c Capacitive or inductive properties
- D Ohmic properties

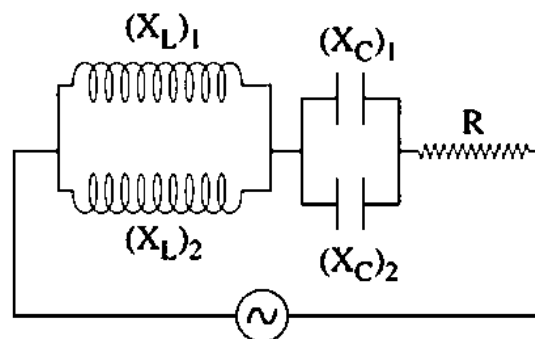

(41) An electron microscope is used to examine two different viruses (A) and (B). And the collected data are recorded in the following table:

The virus	Its dimension (diameter)	The applied potential difference between anode and cathode to examine the virus
A	10 nm	1.5 keV
B	X	37.5 keV

By using these data, the value of (X) equals.....

- A 1 nm
- B 0.4 nm
- c 0.8 nm
- D 2 nm

## Exam (2)

(42) An excited atom gives the wavelength, which are recorded in the opposite figure, due to electron transitions from an excitation energy level to another lower energy level, then the wavelength X is.....

- A 3000 nm
- B 4500 nm
- C 1500 nm
- D 2250 nm

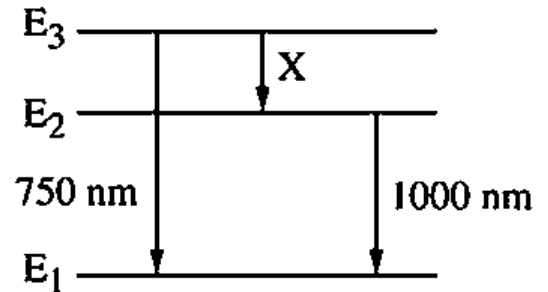

(43) The process of optical pumping with a laser beam is used to produce laser whose active medium is .....

- A gas atoms
- B a crystalline solid
- C a semi-conductor
- D a liquid dye

## Exam (2)

(44) The figure shows a circuit of transistor (npn) as amplifier, so the ratio of  $\frac{\alpha_e}{\beta_e} = \dots\dots\dots$

- A  $2.75 \times 10^{-3}$
- B  $2.13 \times 10^{-2}$
- C  $1.11 \times 10^{-2}$
- D  $2.81 \times 10^{-3}$

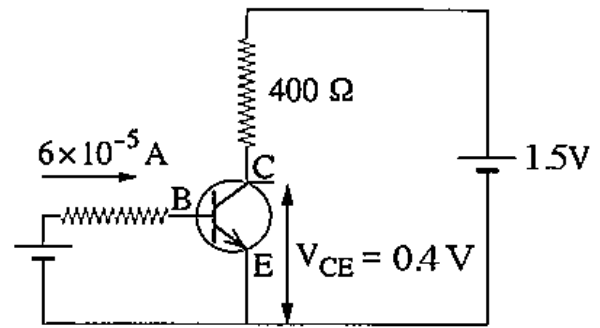

## Exam (2)

### Part (3) Essay questions "Each question has two mark":-

(45) The resistance of a voltmeter is 500 ohms, each of its scale division indicates 0.1 volt, its scale is divided into 10 division, explain how it used:

- (i) For measuring a current of maximum intensity 202 milli-ampere
- (ii) As a voltmeter each of its scale division indicates 1 volt.

(46) A transformer is used to transfer 300 watt, the Voltage across its primary coil 200V and the current in its secondary coil is 5A.

- (i) Calculate the potential of its secondary coil and mention if it's a step up or step-down transformer.
- (ii) What is the factor controlling the output voltage?