

3th
5th Prim
2nd Term

Mr. Mahumoud Moheb

2



MATHEMATICS

Primary Five - Second Term

1

2026





INDEX

Theme (3) | Fractions, Decimals, and Proportional Relationships

Unit (7) | Adding and Subtracting Fractions

Pre-study

(i) Equivalent Fractions	5
(ii) Simplest Form of a Fraction	6

Concept (1) | Adding and Subtracting Fractions with Unlike Denominators

(1) Finding Like Denominators Using the LCM	7
(2) Using Models to Add and Subtract Fractions with Unlike Denominators	9
(3) Adding and Subtracting Fractions with Unlike Denominators	10
(4) More of Adding and Subtracting Fractions with Unlike Denominators	11

Unit (8) | Adding and Subtracting Mixed Numbers

Concept (1) | Working with Mixed Numbers

(1) Adding and Subtracting Mixed Numbers with Like Denominators	17
(2) Finding Like Denominators of the Mixed Numbers	18

Concept (2) | Adding and Subtracting Mixed Numbers with Unlike Denominators

(3) Using Models to Add and Subtract Mixed Numbers	21
(4) Adding and Subtracting Mixed Numbers	22
(5) More of Adding and Subtracting Mixed Numbers	23
(6) Story Problems with Mixed Numbers	24

Unit (9) | Multiplying and Dividing Fractions

Concept (1) | Multiplying Fractions and Mixed Numbers

(1) Multiplying a Fraction or a Mixed Numbers by a Whole Number	29
(2) Multiplying Fractions Using Models	31
(3) Multiplying Fractions by Fractions	31
(4) Multiplying Fractions and Mixed Numbers	33
(5) Multiplying Mixed Numbers Using Improper Fractions	33
(6) Story Problems Involving Multiplication of Fractions and Mixed Numbers	33

Concept (2) | Dividing Whole Numbers and Unit Fractions

(7) Convert Improper Fraction to Mixed Number	38
(8) Dividing Unit Fractions by Whole Numbers	39
(9) Dividing Whole Numbers by Unit Fractions	39
(10) Story Problems Involving Division of Whole Numbers and Unit Fractions	40



Theme (4) | Applications of Geometry and Measurement

Unit (10) | Two-Dimensional Figures and Coordinates Plane

Concept (1) | Investigating Attributes of Shapes

(1) Classifying of Geometric Shapes	47
(2) Tricky Triangles	49
(3) Calculating Area with Fractional Dimensions	55
(4) Applying the Area Formula	55

Concept (2) | Coordinates Plane

(5) Exploring the Coordinate Plane	58
(6) Plotting Points on a coordinate Plane	59
(7) Coordinate Designs	60
(8) Representing Points and Creating Patterns	61
(9) Graphing Real-World Data	62

Unit (11) | Volume

Concept (1) | Understanding Volume and Capacity

(1) Geometric Shapes around Us	69
(2) Measuring Volume in Cube Units	72
(3) Same Volume, Different Shape	72

Concept (2) | Measuring Volume

(4) Finding Formula	78
(5) Using a Formula to Find Volume	79
(6) Finding the Volume of Compound Shapes	80
(7) Solving Real-World Volume Story Problems	81

Unit (12) | Pie Charts

Concept (1) | Understanding Pie Charts

(1) Exploring Pie Charts	88
(2) Interpreting Data in a Pie Chart	91
(3) Making Pie Chart	92





UNIT

7

Theme 3 | Fractions, Decimals, and Proportional Relationships

Unit 7 Adding and Subtracting Fractions

Photo Credit: Konstantin Zauwan / Shutterstock.com



Pre-Study

Lesson (i)

Equivalent Fractions

Complete to find equivalent fractions.

a.

$$\frac{1}{3} = \frac{\square}{\square}$$

$\times 4$ (top arrow) and $\times 4$ (bottom arrow)

b.

$$\frac{3}{6} = \frac{\square}{\square}$$

$\div 3$ (top arrow) and $\div 3$ (bottom arrow)

c.

$$\frac{2}{7} = \frac{\square}{\square}$$

$\times 2$ (top arrow) and $\times 2$ (bottom arrow)

d.

$$\frac{4}{16} = \frac{\square}{\square}$$

$\div 4$ (top arrow) and $\div 4$ (bottom arrow)



1. Complete.

$$\frac{2}{8} = \frac{6}{\square} = \frac{\square}{16} = \frac{\square}{4} = \frac{\square}{\square}$$

$$\frac{12}{18} = \frac{6}{\square} = \frac{\square}{6} = \frac{\square}{\square}$$



Complete.

a. $\frac{2}{3} = \frac{\square}{9}$

b. $\frac{4}{6} = \frac{12}{\square}$

c. $\frac{3}{6} = \frac{\square}{2}$

d. $\frac{2}{7} = \frac{\square}{14}$

e. $\frac{8}{10} = \frac{4}{\square}$

f. $\frac{\square}{6} = \frac{10}{12}$



Complete to find an equivalent fraction.

a.

$$\frac{1}{3} = \frac{\square}{\square}$$

$\times 4$ (top arrow) and $\times 4$ (bottom arrow)

b.

$$\frac{2}{5} = \frac{\square}{\square}$$

$\times 5$ (top arrow) and $\times 5$ (bottom arrow)

c.

$$\frac{3}{7} = \frac{\square}{\square}$$

$\times 2$ (top arrow) and $\times 2$ (bottom arrow)

d.

$$\frac{3}{6} = \frac{\square}{\square}$$

$\div 3$ (top arrow) and $\div 3$ (bottom arrow)

e.

$$\frac{4}{8} = \frac{\square}{\square}$$

$\div 4$ (top arrow) and $\div 4$ (bottom arrow)

f.

$$\frac{20}{50} = \frac{\square}{\square}$$

$\div 10$ (top arrow) and $\div 10$ (bottom arrow)



Lesson (ii)

Simplest Form of a Fraction

Complete to Simplify the Fractions:

$\frac{14}{35} = \frac{\dots}{\dots}$	$\frac{3}{18} = \frac{\dots}{\dots}$	$\frac{10}{15} = \frac{\dots}{\dots}$
$\frac{16}{32} = \frac{\dots}{\dots}$	$\frac{33}{44} = \frac{\dots}{\dots}$	$\frac{24}{40} = \frac{\dots}{\dots}$



Simplify:

a $\frac{5}{10} = \frac{\dots}{\dots}$

b $\frac{2}{6} = \frac{\dots}{\dots}$

c $\frac{6}{12} = \frac{\dots}{\dots}$

d $\frac{6}{9} = \frac{\dots}{\dots}$

e $\frac{5}{20} = \frac{\dots}{\dots}$

f $\frac{6}{21} = \frac{\dots}{\dots}$

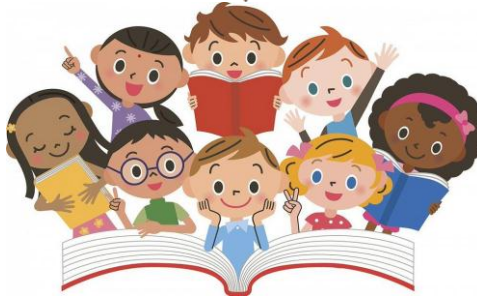



Concept (7-1)

Lesson (1)

Finding Like Denominators Using the LCM

Change into like denominator fractions:

a. $\frac{7}{8}, \frac{5}{24}$

b. $\frac{5}{22}, \frac{9}{11}$

c. $\frac{8}{15}, \frac{5}{6}$



Choose the correct answer:

1. The L.C.M of the denominators of $\frac{7}{12}$ and $\frac{5}{18}$ is _____

- A. 12 B. 36
C. 18 D. 6

2. The smallest like denominator of $\frac{1}{6}$ and $\frac{4}{5}$ is _____

- A. 5 B. 4
C. 30 D. 6

3. The smallest common denominator of the fractions $\frac{2}{3}$ and $\frac{4}{9}$ is _____

- A. 3 B. 6
C. 9 D. 12

4. Which of the following is not equivalent to $\frac{15}{20}$?

- A. $\frac{3}{4}$ B. $\frac{30}{40}$
C. $\frac{25}{100}$ D. $\frac{9}{12}$

5. The fractions which are equivalent to $\frac{5}{6}$ and $\frac{7}{8}$ with the like denominator are _____

- A. $\frac{15}{18}, \frac{14}{18}$ B. $\frac{20}{48}, \frac{42}{48}$ C. $\frac{10}{12}, \frac{10}{12}$ D. $\frac{20}{24}, \frac{21}{24}$

6. Which of the following is equivalent to the pair of fractions $\frac{5}{6}$ and $\frac{1}{4}$ using the L.C.M of their denominators ?

- A. $\frac{20}{24}, \frac{6}{24}$ B. $\frac{10}{16}, \frac{4}{16}$ C. $\frac{10}{12}, \frac{3}{12}$ D. $\frac{40}{48}, \frac{12}{48}$

7. The two like denominator fractions represent the models   are _____

- A. $\frac{3}{4}, \frac{1}{3}$ B. $\frac{6}{8}, \frac{2}{8}$ C. $\frac{8}{12}, \frac{4}{12}$ D. $\frac{9}{12}, \frac{4}{12}$





Homework

Change into like denominator fractions:

a. $\frac{4}{9}$ and $\frac{2}{3}$

b. $\frac{1}{3}$ and $\frac{2}{7}$

c. $\frac{1}{5}$ and $\frac{1}{4}$

d. $\frac{2}{9}$ and $\frac{7}{12}$

e. $\frac{5}{6}$ and $\frac{3}{8}$

f. $\frac{2}{3}$ and $\frac{1}{4}$

g. $\frac{3}{4}$ and $\frac{5}{12}$

h. $\frac{5}{8}$ and $\frac{7}{12}$



Complete:

a. The L.C.M of the denominators of $\frac{4}{5}$ and $\frac{2}{25}$ is _____b. The L.C.M of the denominators of $\frac{1}{3}$ and $\frac{5}{12}$ is _____c. The smallest like denominator of $\frac{2}{3}$ and $\frac{3}{4}$ is _____d. The L.C.M of the denominators of $\frac{2}{5}$ and $\frac{1}{3}$ is _____

Complete to get equivalent fractions:

$$\frac{5}{8} = \frac{\dots\dots\dots}{\dots\dots\dots}$$

(x4) (x4)

$$\frac{2}{6} = \frac{\dots\dots\dots}{\dots\dots\dots}$$

(x2) (x2)

$$\frac{1}{9} = \frac{\dots\dots\dots}{\dots\dots\dots}$$

(x6) (x6)

$$\frac{20}{30} = \frac{\dots\dots\dots}{\dots\dots\dots}$$

(x4) (x4)

$$\frac{6}{12} = \frac{\dots\dots\dots}{\dots\dots\dots}$$

(x7) (x7)

$$\frac{7}{9} = \frac{\dots\dots\dots}{\dots\dots\dots}$$

(x8) (x8)



Lesson (2)

Using Models to Add and Subtract Fractions
with Unlike Denominators

Use the fraction wall to evaluate each sum or difference:

(1) $\frac{1}{2} + \frac{1}{3} = \dots\dots\dots$

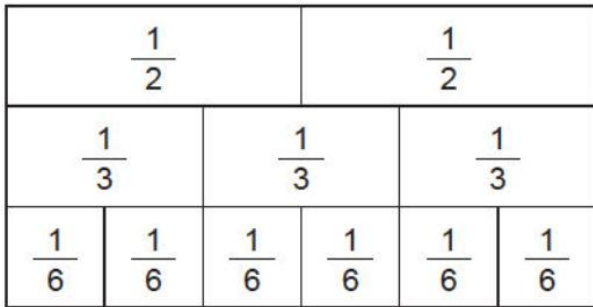

(2) $\frac{1}{2} + \frac{1}{4} = \dots\dots\dots$

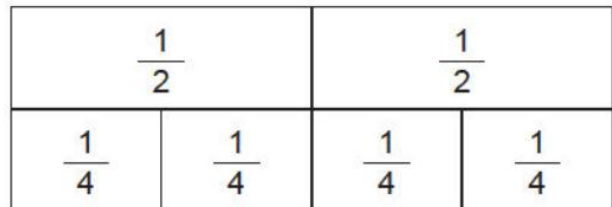

(3) $\frac{3}{6} + \frac{1}{4} = \dots\dots\dots$

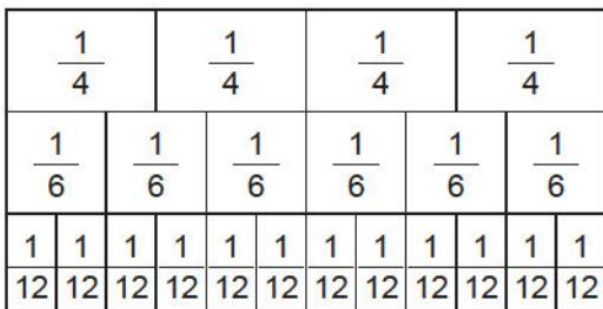

(4) $\frac{7}{10} - \frac{2}{5} = \dots\dots\dots$

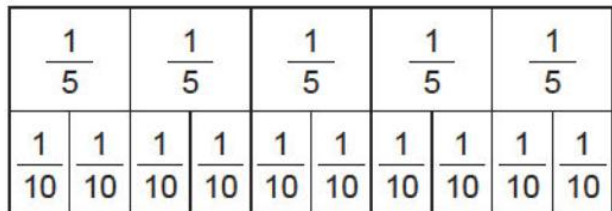

(5) $\frac{3}{5} - \frac{1}{2} = \dots\dots\dots$

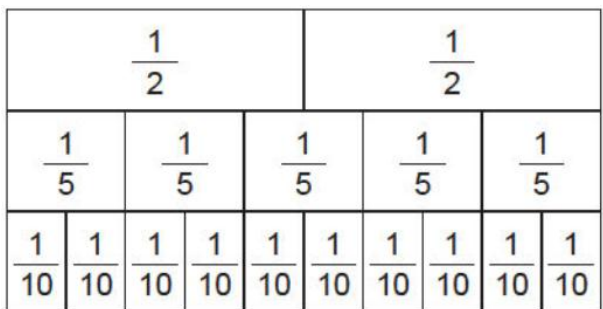

(6) $\frac{9}{12} - \frac{1}{6} = \dots\dots\dots$

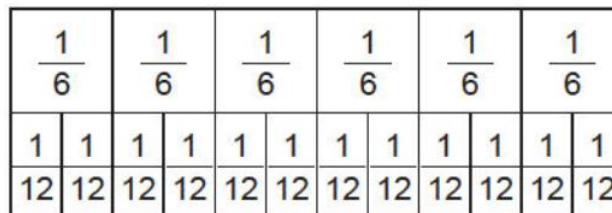



Lesson (3)

Adding and Subtracting Fractions
with Unlike Denominators

Evaluate by rewriting the fractions with like denominators:

a. $\frac{5}{16} + \frac{3}{8}$ _____

c. $\frac{2}{7} + \frac{3}{14}$ _____

b. $\frac{7}{9} - \frac{1}{3}$ _____

d. $\frac{7}{10} - \frac{1}{5}$ _____



Evaluate by rewriting the fractions with like denominators:

1. $\frac{3}{5} + \frac{1}{3} =$ _____

2. $\frac{11}{12} - \frac{7}{8} =$ _____

3. $\frac{1}{5} + \frac{1}{2} =$ _____

4. $\frac{5}{9} + \frac{1}{2} =$ _____

5. $\frac{3}{4} - \frac{1}{3} =$ _____

6. $\frac{1}{2} + \frac{1}{3} =$ _____





Lesson (4)

More of Adding and Subtracting Fractions with Unlike Denominators

Choose the correct answer :

a. If $\frac{1}{15} + \frac{2}{5} = \frac{1}{15} + \frac{x}{15}$, then $x =$ _____

A. $\frac{6}{15}$

B. $\frac{3}{20}$

C. $\frac{7}{15}$

D. 6

b. The sum of $(\frac{2}{3} + \frac{7}{9}) =$ _____

A. $1\frac{2}{9}$

B. $\frac{2}{9}$

C. $1\frac{4}{9}$

D. $\frac{4}{9}$



Find the value of k in each of the following .

1. $\frac{1}{4} + k = \frac{7}{8}$ _____

2. $k - \frac{1}{5} = \frac{1}{6}$ _____

3. $\frac{2}{3} - k = \frac{1}{4}$ _____



Maha has $\frac{1}{2}$ kg of flour. She used $\frac{2}{5}$ kg of it. What is the rest with her ?





Homework

Evaluate by rewriting the fractions with like denominators:

1. $\frac{1}{3} + \frac{1}{4} =$ _____

2. $\frac{1}{3} - \frac{1}{4} =$ _____

3. $\frac{1}{2} + \frac{2}{5} =$ _____

4. $\frac{1}{2} - \frac{2}{5} =$ _____

5. $\frac{5}{6} + \frac{3}{8} =$ _____

6. $\frac{5}{6} - \frac{3}{8} =$ _____



Evaluate by rewriting the fractions with like denominators:

1. $\frac{1}{6} + \frac{5}{8} =$ _____

2. $\frac{7}{9} - \frac{1}{6} =$ _____

3. $\frac{1}{8} + \frac{3}{5} + \frac{9}{10} =$ _____



Karim walked $\frac{1}{5}$ km and Sameh walked $\frac{1}{3}$ km more. What distance that Sameh walked ?



Add:

1. $\frac{1}{3} + \frac{1}{4} =$ _____

2. $\frac{1}{4} + \frac{1}{8} =$ _____

3. $\frac{1}{4} + \frac{3}{10} =$ _____

**Subtract:**

1. $\frac{5}{6} - \frac{2}{3} =$ _____

2. $\frac{2}{5} - \frac{1}{10} =$ _____

3. $\frac{5}{6} - \frac{3}{8} =$ _____





Unit (7) Assessment

[A] Choose the correct answer:

(1) $\frac{5}{7} + \frac{3}{14} = \dots\dots\dots$

a $\frac{2}{7}$

b $\frac{13}{14}$

c $\frac{8}{21}$

d $\frac{8}{14}$

(2) $\frac{2}{5} + \frac{3}{10} = \dots\dots\dots$

a $\frac{5}{15}$

b $\frac{7}{10}$

c $\frac{5}{10}$

d $\frac{1}{2}$

(3) $\frac{3}{4} - \frac{3}{5} = \dots\dots\dots$

a 0

b $\frac{1}{20}$

c $\frac{3}{20}$

d $\frac{6}{20}$

(4) $\frac{5}{6} - \frac{3}{5} = \dots\dots\dots$

a 2

b $\frac{7}{30}$

c $\frac{2}{30}$

d $\frac{2}{25}$

(5) $\frac{5}{8} - \frac{1}{2} = \dots\dots\dots$

a 1

b $\frac{2}{3}$

c $1\frac{1}{8}$

d $\frac{1}{8}$

(6) $\frac{5}{12} + \frac{1}{6} = \dots\dots\dots$

a $\frac{3}{12}$

b $\frac{7}{12}$

c $\frac{5}{12}$

d $\frac{1}{12}$

(7) $\frac{6}{16} + \frac{1}{4} = \dots\dots\dots$

a $\frac{7}{16}$

b $\frac{7}{20}$

c $\frac{5}{8}$

d $\frac{1}{8}$





[B] Complete:

(1) The smallest common denominator of $\frac{1}{3}$ and $\frac{3}{5}$ is

(2) $\frac{1}{6} + \frac{11}{12} + \frac{1}{3} =$

(3) $\frac{3}{22} + \frac{8}{11} =$

(4) $\frac{7}{10} - \frac{9}{20} - \frac{1}{5} =$



[C] Write the equivalent fraction to have like denominators:

(1) $\frac{5}{6}$, $\frac{8}{9}$

(2) $\frac{2}{3}$, $\frac{2}{9}$

(3) $\frac{3}{4}$, $\frac{4}{5}$



[D] Story problems:

(1) A baker has $\frac{8}{9}$ kg of flour. He used $\frac{5}{6}$ kg. How much kg of flour was left?

(2) Ali has 12 balls 4 of them are blue, 3 are green, 3 are yellow, and the remaining are red. What is the fraction that represents the red balls?





UNIT

8

Theme 3 | Fractions, Decimals, and
Proportional Relationships

Unit 8

Adding and Subtracting Mixed Numbers

Photo Credit: Segitarus_13 / Shutterstock.com





Concept (8-1)

Lesson (1)

Adding and Subtracting Mixed Numbers with Like Denominators

Complete the chart by rewriting the given values in two other forms:

	Mixed Number	Equivalent Improper Fraction	Equivalent Mixed Number
1.	$3\frac{1}{3}$	$\frac{\dots}{\dots}$	$2\frac{\dots}{\dots}$
2.	$2\frac{5}{8}$	$\frac{\dots}{\dots}$	$1\frac{\dots}{\dots}$
3.	$\frac{\dots}{\dots}$	$\frac{28}{5}$	$3\frac{\dots}{\dots}$
4.	$4\frac{3}{4}$	$\frac{\dots}{\dots}$	$3\frac{\dots}{\dots}$
5.	$\frac{\dots}{\dots}$	$\frac{9}{2}$	$2\frac{\dots}{\dots}$
6.	$\frac{\dots}{\dots}$	$\frac{22}{4}$	$3\frac{\dots}{\dots}$



Evaluate each sum or difference. Simplify if possible:

a. $2\frac{1}{5} + 3\frac{3}{5}$ _____

c. $3\frac{3}{8} + 1\frac{5}{8}$ _____

b. $4\frac{2}{3} - 1\frac{1}{3}$ _____

d. $5\frac{2}{7} - 3\frac{5}{7}$ _____





Solve Each Equation

1. $3\frac{1}{5} + b = 5\frac{3}{5}$ $b =$ _____

2. $c + 4\frac{2}{3} = 5\frac{1}{3}$ $c =$ _____

3. $2\frac{4}{8} - d = 1\frac{1}{8}$ $d =$ _____

4. $f + 1\frac{3}{4} = 7\frac{1}{4}$ $f =$ _____



Lesson (2)

Finding Like Denominators of the Mixed Numbers

Rewrite the given mixed numbers with like denominators in two different ways:

	First Rewrite	Second Rewrite
1. $1\frac{3}{4}$ and $1\frac{6}{15}$	A. _____ and _____	B. _____ and _____
2. $3\frac{6}{8}$ and $2\frac{8}{12}$	A. _____ and _____	B. _____ and _____
3. $2\frac{9}{18}$ and $2\frac{14}{24}$	A. _____ and _____	B. _____ and _____

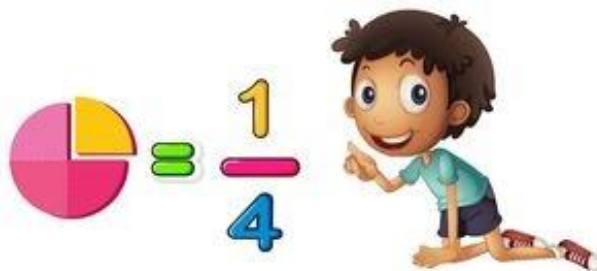



Homework

Evaluate each sum or difference. Simplify if possible:

a. $1\frac{3}{5} + 3\frac{1}{5} =$ _____

b. $2\frac{5}{6} + 2\frac{3}{6} =$ _____

c. $7\frac{1}{6} + 1\frac{3}{6} =$ _____

d. $4\frac{4}{9} + 1\frac{1}{9} =$ _____

e. $8\frac{3}{7} - 8\frac{1}{7} =$ _____

f. $1\frac{2}{3} + 3\frac{2}{3} =$ _____



Solve Each Equation

5. $g - \frac{7}{8} = \frac{6}{8}$ $g =$ _____

6. $2\frac{2}{3} - h = 1$ $h =$ _____

7. $j + 3\frac{3}{4} = 9\frac{2}{4}$ $j =$ _____

8. $8\frac{1}{5} - k = 5\frac{3}{5}$ $k =$ _____



Rewrite the given mixed numbers with like denominators in two different ways:

	First Rewrite	Second Rewrite
4. $3\frac{12}{16}$ and $1\frac{15}{24}$	A. _____ and _____	B. _____ and _____

5. $10\frac{5}{6}$ and $5\frac{15}{27}$	A. _____ and _____	B. _____ and _____
---	--------------------	--------------------





Choose the correct answer:

1. $4\frac{3}{7} + 1\frac{5}{7} =$ _____

A. $5\frac{1}{7}$

B. $6\frac{1}{7}$

C. $5\frac{8}{14}$

D. $6\frac{2}{7}$

2. $5\frac{5}{8} - 3\frac{2}{8} =$ _____

A. $8\frac{2}{8}$

B. $\frac{2}{8}$

C. $2\frac{1}{4}$

D. $2\frac{3}{8}$

3. $1\frac{2}{5} + 2\frac{3}{5} =$ _____

A. 5

B. 6

C. 4

D. $3\frac{5}{10}$

4. If $4\frac{3}{5} + k = 6\frac{2}{5}$, then $k =$ _____

A. $1\frac{4}{5}$

B. 11

C. $2\frac{1}{5}$

D. $1\frac{3}{5}$

5. If $3\frac{4}{7} - x = 2\frac{1}{7}$, then $x =$ _____

A. $\frac{3}{7}$

B. 1

C. $1\frac{5}{7}$

D. $1\frac{3}{7}$

6. $K - 2\frac{1}{3} = 1\frac{1}{3}$, then $K =$ _____

A. $3\frac{2}{3}$

B. $3\frac{1}{3}$

C. $1\frac{2}{3}$

D. $2\frac{2}{3}$

7. The fraction $3\frac{2}{5}$ by regrouping is _____

A. $\frac{15}{5}$

B. $2\frac{7}{5}$

C. $1\frac{7}{5}$

D. $\frac{16}{5}$

8. $9\frac{4}{7} - 9\frac{1}{7} =$ _____

A. 0

B. $9\frac{3}{7}$

C. $\frac{3}{7}$

D. $1\frac{2}{7}$

9. $\frac{19}{5}$ is equivalent to _____

A. $3\frac{3}{5}$

B. $4\frac{1}{5}$

C. $3\frac{5}{5}$

D. $3\frac{4}{5}$

10. $2\frac{1}{3}$ can be regrouped as _____

A. $1\frac{4}{3}$

B. $\frac{3}{7}$

C. $1\frac{2}{3}$

D. 7





Concept (8-2)

Lesson (3)

Using Models to Add and Subtract Mixed Numbers

Use an area model to find the sum

$$2\frac{2}{3} + 1\frac{1}{2} = \dots\dots\dots$$

Step 1 : Modeling

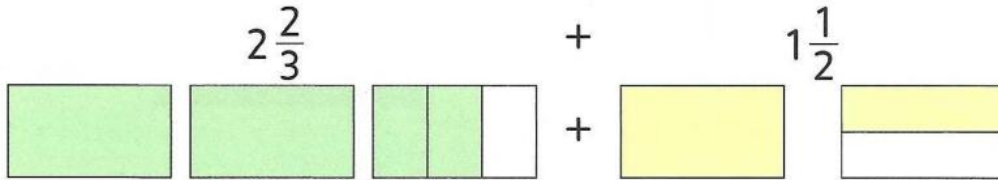

Step 2 : Dividing

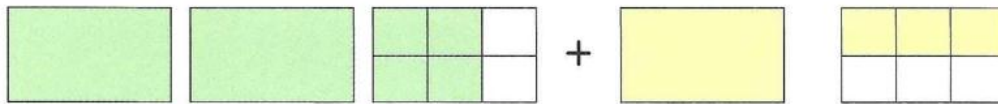

Step 3 : Adding

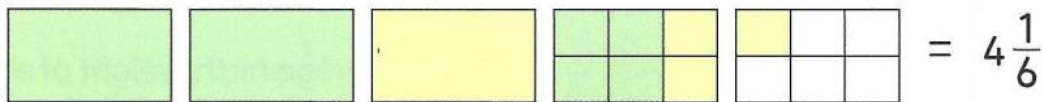

Use an area model to find the difference:

$$2\frac{2}{3} - 1\frac{1}{2} = \dots\dots\dots$$

Step 1 : Modeling

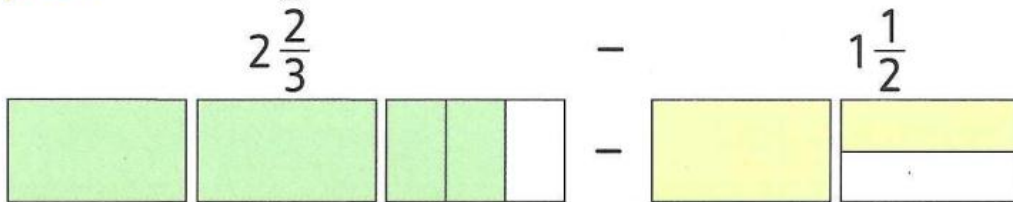

Step 2 : Dividing



Step 3 : Subtracting

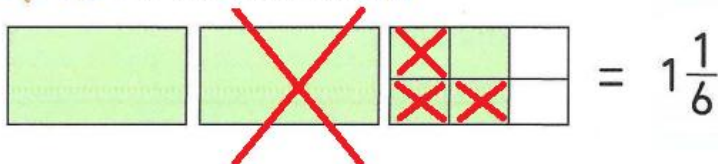



Subtract $5\frac{1}{3} - 2\frac{1}{2}$ using a number line.

Step 1: Draw a number line.



Step 2: Jump from subtrahend to minuend.

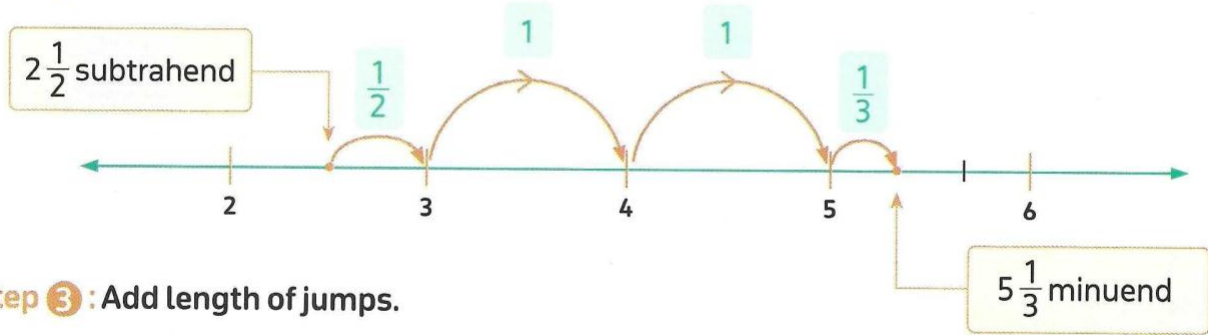

Step 3: Add length of jumps.

$$\text{The difference} = \frac{1}{2} + 1 + 1 + \frac{1}{3} = \frac{3}{6} + 2 + \frac{2}{6} = 2\frac{5}{6}$$



Lesson (4)

Adding and Subtracting Mixed Numbers

Evaluate then simplify if possible:

a. $3\frac{1}{2} + 2\frac{1}{4}$ _____

b. $3\frac{1}{8} + 2\frac{1}{3}$ _____

c. $2\frac{2}{5} + 1\frac{1}{2}$ _____

d. $6\frac{1}{6} + 7\frac{1}{7}$ _____

e. $9\frac{2}{3} + 8\frac{1}{5}$ _____

f. $6\frac{4}{5} + 4\frac{2}{3}$ _____

g. $2\frac{5}{6} + \frac{8}{9}$ _____

h. $1\frac{2}{5} + \frac{5}{10}$ _____





Evaluate then simplify if possible:

a. $6\frac{2}{3} - 3\frac{1}{4}$ _____

b. $3\frac{3}{6} - 2\frac{1}{3}$ _____

c. $1\frac{4}{7} - \frac{10}{21}$ _____

d. $2 - \frac{3}{4}$ _____

e. $7 - 2\frac{3}{5}$ _____

f. $5\frac{5}{8} - 1\frac{1}{3}$ _____

g. $9\frac{1}{6} - 4\frac{4}{9}$ _____

h. $1\frac{2}{5} - \frac{5}{10}$ _____



Lesson (5)

More of Adding and Subtracting Mixed Numbers

Find the missing number using any strategy. Simplify if possible:

a. $a + 5\frac{5}{6} = 9\frac{1}{12}$, $a =$ _____

b. $8\frac{7}{10} - b = 4\frac{9}{20}$, $b =$ _____

c. $9\frac{5}{20} - c = 4\frac{19}{20}$, $c =$ _____

d. $f + 9\frac{1}{4} = 12\frac{15}{16}$, $f =$ _____





Lesson (6)

Story Problems with Mixed Numbers

Complete:

- a. $5\frac{2}{3}$ minutes = _____ minutes and _____ seconds
- b. $6\frac{3}{5}$ hours = _____ hours and _____ minutes
- c. $3\frac{1}{2}$ years = _____ years and _____ months
- d. 75 seconds = _____ minute



Choose the correct answer:

- a. $1\frac{1}{8}$ days = _____ hours
 A. 24 B. 8 C. 27 D. 18
- b. $2\frac{1}{3}$ hours = _____ minutes
 A. 120 B. 150 C. 140 D. 130
- c. 36 months = _____ years
 A. $2\frac{1}{2}$ B. $1\frac{1}{2}$ C. 3 D. $3\frac{1}{2}$



Marwa took $2\frac{1}{3}$ hours to paint a table and $1\frac{1}{4}$ hours to paint a chair.

How much time did she take in all ?



Karim walked $2\frac{1}{5}$ km and Sameh walked $1\frac{1}{3}$ km more.

What distance that Sameh walked ?





Homework

Evaluate and simplify if possible:

6. $3\frac{4}{5} + 2\frac{2}{3}$ Evaluate: _____

7. $9\frac{1}{6} - 3\frac{1}{3}$ Evaluate: _____

8. $1\frac{2}{3} - 1\frac{3}{5}$ Evaluate: _____

9. $4\frac{3}{4} + 9\frac{5}{12}$ Evaluate: _____

10. $2\frac{1}{4} + 1\frac{11}{16}$ Evaluate: _____



Find the missing number using any strategy. Simplify if possible:

e. $f + 9\frac{1}{4} = 12\frac{15}{16}$, $f =$ _____

f. $g - 1\frac{3}{4} = 7\frac{3}{44}$, $g =$ _____

g. $4\frac{12}{18} + h = 11$, $h =$ _____

h. $j - 4\frac{7}{8} = 4\frac{37}{40}$, $j =$ _____



Farida bought $2\frac{1}{2}$ kg of tomato, $1\frac{3}{8}$ kg of onion and $5\frac{1}{4}$ kg of potatoes.

How much vegetables did she buy ?



A vessel contains $1\frac{1}{2}$ liters of milk. Ahmed drinks $\frac{1}{4}$ liter of milk and Sara drinks $\frac{1}{2}$ liter of milk.

How much of milk is left in the vessel ?



Unit (8) Assessment

[A] Choose the correct answer:

1. $2\frac{3}{5} + 1\frac{4}{5} =$ _____
 A. $3\frac{7}{10}$ B. $4\frac{2}{5}$ C. $1\frac{1}{5}$ D. $2\frac{7}{5}$
2. $5\frac{2}{7} + k = 6\frac{5}{7}$, then k = _____
 A. $11\frac{7}{7}$ B. $1\frac{3}{7}$ C. $4\frac{3}{7}$ D. $5\frac{1}{7}$
3. $2\frac{1}{4}$ years = _____ months.
 A. 27 B. 54 C. 135 D. 180
4. Two fractions $3\frac{2}{3}$ and $5\frac{1}{6}$ with like denominators are _____
 A. $3\frac{2}{3}$ and $5\frac{1}{6}$ B. $\frac{11}{3}$ and $\frac{31}{3}$ C. $3\frac{4}{6}$ and $5\frac{1}{6}$ D. $3\frac{2}{3}$ and $5\frac{2}{6}$
5. $2\frac{3}{5} +$ _____ = $3\frac{1}{4}$
 A. $\frac{13}{20}$ B. $1\frac{1}{4}$ C. $1\frac{4}{5}$ D. $1\frac{2}{5}$
6. $2\frac{1}{3}$ hours = _____ minutes
 A. 150 B. 120 C. 130 D. 140
7. $\frac{17}{3}$ is equivalent to _____
 A. $3\frac{1}{6}$ B. $7\frac{1}{2}$ C. $3\frac{2}{5}$ D. $5\frac{2}{3}$



[B] Complete:

1. $3\frac{1}{2} - 2\frac{3}{5} =$ _____
2. $g - 1\frac{3}{4} = 7\frac{3}{44}$, then g = _____
3. $7\frac{2}{5} + 1\frac{1}{4} = 8 + 1 + \frac{1}{4} -$ _____
4. $9\frac{1}{4} -$ _____ = $3\frac{3}{4}$
5. $\frac{1}{2}$ year = _____ months
6. 150 seconds = _____ minutes
7. $X + 5\frac{1}{2} = 7\frac{3}{4}$, then X = _____
8. $2\frac{3}{7}$ as an improper fraction is _____



[C] Choose the correct answer:

- $1\frac{5}{8} + 2\frac{7}{12} + \frac{1}{4} =$ _____
 A. $3\frac{7}{12}$ B. $4\frac{5}{6}$ C. $4\frac{7}{12}$ D. $4\frac{11}{24}$
- $2\frac{4}{5} + 1\frac{3}{10} - 1\frac{1}{2} =$ _____
 A. $\frac{6}{5}$ B. $3\frac{2}{5}$ C. $1\frac{7}{10}$ D. $2\frac{3}{5}$
- $4\frac{3}{5} \neq$ _____
 A. $8\frac{6}{10}$ B. $\frac{23}{5}$ C. $4\frac{6}{10}$ D. $3\frac{8}{5}$
- If $3\frac{2}{3} - b = 1$, then $b =$ _____
 A. $3\frac{2}{3}$ B. $2\frac{2}{3}$ C. $\frac{2}{3}$ D. 2
- The fraction $2\frac{1}{4}$ by regrouping is _____
 A. $2\frac{5}{4}$ B. $1\frac{5}{4}$ C. $1\frac{2}{4}$ D. $\frac{5}{4}$
- $4\frac{5}{6} - 2\frac{1}{12} =$ _____
 A. $2\frac{3}{4}$ B. $3\frac{4}{3}$ C. $5\frac{5}{4}$ D. $2\frac{2}{7}$
- $5\frac{1}{4} -$ _____ $= 3\frac{1}{2}$
 A. $\frac{3}{4}$ B. $1\frac{3}{4}$ C. $4\frac{3}{4}$ D. $8\frac{3}{4}$



[D] Answer the following:

- Marwan studied Math for $2\frac{1}{2}$ hours and Science for 90 minutes.
 How many hours did Marwan study in all ?

- Sameh ate $1\frac{3}{4}$ kg of fruits, Bassem ate $\frac{1}{5}$ kg more than Sameh and Wael ate $\frac{1}{2}$ kg less than Sameh.
 How many kg of fruits did the three friends eat together ?





UNIT

9

Theme 3 | Fractions, Decimals, and Proportional Relationships

Unit 9 Multiplying and Dividing Fractions

Photo Credit: zaynab / Shutterstock.com





Concept (9-1)

Lesson (1)

Multiplying a Fraction or a Mixed by a Whole

Multiply, and then write the result in its simplest form:

a. $\frac{1}{3} \times 5 =$

b. $4 \times \frac{1}{4} =$

c. $\frac{2}{7} \times 21 =$

d. $\frac{3}{5} \times 15 =$

e. $9 \times \frac{5}{6} =$

f. $\frac{1}{25} \times 10 =$

g. $2\frac{3}{8} \times 4 =$

h. $5\frac{1}{4} \times 8 =$

i. $2\frac{2}{5} \times 10 =$

j. $2\frac{1}{5} \times 10 =$



As a caretaker, Ezz walks the perimeter of the garden 3 days per week. The perimeter of the garden is $2\frac{1}{5}$ kilometers. What is the total distance Ezz walks each week ?





Ezz notices that $\frac{2}{3}$ of the 6 rose bushes are in bloom. How many rose bushes are in bloom ?



Complete:

a. $\frac{4}{11} \times \text{————} = \frac{4}{11} + \frac{4}{11} + \frac{4}{11} + \frac{4}{11}$

b. If $2\frac{1}{7} = \frac{x}{7}$, then $x = \text{————}$

c. $2\frac{1}{5} \times 2 = \text{————}$

d. $\frac{2}{3}$ of 9 = ————

e. $1\frac{2}{7} \times 3 = 1 \times 3 + \text{————} \times \text{————}$

f. $7\frac{2}{3} \times 4 = \text{————} \times \text{————} + \frac{2}{3} \times 4$

g. If $2\frac{1}{4} \times 8 = [\frac{1}{4} \times b] + [2 \times 8]$, then $b = \text{————}$

h. $2\frac{1}{2} \times 5 = [\text{————} \times 5] + [\frac{1}{2} \times 5]$

i. $\frac{5}{3} \times 6 \times \frac{2}{7} = \text{————}$

j. $\frac{2}{5} \times 20 \times \frac{3}{4} = \text{————}$

k. $2\frac{4}{5} \times 3 = 3 \times \frac{\text{—}}{\text{—}}$

l. $5 \times 3\frac{2}{11} = \frac{\text{—}}{\text{—}} \times 5$

m. If $a \times \frac{3}{17} = \frac{3}{17}$, then $a = \text{————}$

n. If $\frac{7}{8} \times 12 = \frac{14}{8} \times x$, then $x = \text{————}$





Lesson (2)

Multiplying Fractions Using Models

Missing Numbers Study the multiplication area models and fill in the missing fraction. Then, enter the product. Simplify your answers, if possible.

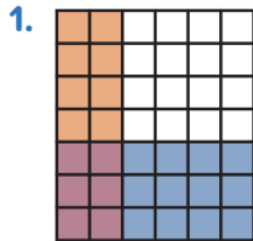

$$\frac{2}{6} \times \underline{\hspace{2cm}} = \underline{\hspace{2cm}}$$

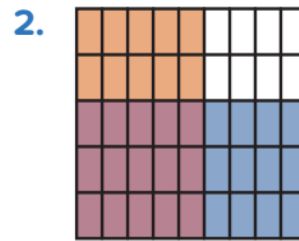

$$\underline{\hspace{2cm}} \times \frac{3}{5} = \underline{\hspace{2cm}}$$



$$\frac{5}{8} \times \underline{\hspace{2cm}} = \underline{\hspace{2cm}}$$

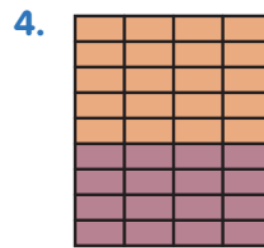

$$\underline{\hspace{2cm}} \times \frac{4}{9} = \underline{\hspace{2cm}}$$



Lesson (3)

Multiplying Fraction by Fraction

1. $\frac{1}{2} \times \frac{1}{5} = \underline{\hspace{2cm}}$

5. $\frac{3}{4} \times \frac{1}{2} = \underline{\hspace{2cm}}$

2. $\frac{5}{6} \times \frac{2}{5} = \underline{\hspace{2cm}}$

6. $\frac{3}{6} \times \frac{5}{6} = \underline{\hspace{2cm}}$

3. $\frac{3}{5} \times \frac{1}{4} = \underline{\hspace{2cm}}$

7. $\frac{3}{4} \times \frac{3}{8} = \underline{\hspace{2cm}}$

4. $\frac{1}{3} \times \frac{3}{8} = \underline{\hspace{2cm}}$

8. $\frac{5}{8} \times \frac{3}{3} = \underline{\hspace{2cm}}$





Let's Multiply Find the product. Simply your answers, if possible.

1. $\frac{1}{2} \times \frac{2}{8} =$ _____

4. $\frac{1}{4} \times \frac{1}{4} =$ _____

2. $\frac{1}{3} \times \frac{2}{7} =$ _____

5. $\frac{5}{10} \times \frac{8}{10} =$ _____

3. $\frac{3}{9} \times \frac{3}{4} =$ _____



Homework

Make It Simpler Write each product in its simplest form.

1. $\frac{3}{8} \times \frac{1}{6} =$ _____

2. $\frac{1}{4} \times \frac{8}{11} =$ _____

3. $\frac{4}{5} \times \frac{4}{9} =$ _____

4. $\frac{5}{12} \times \frac{3}{5} =$ _____

5. $\frac{5}{8} \times \frac{2}{15} =$ _____





Choose the correct answer:

1. $\frac{2}{15} \times \frac{5}{6} =$ _____

- A.
- $\frac{1}{3}$
- B.
- $\frac{1}{6}$
- C.
- $\frac{1}{8}$
- D.
- $\frac{1}{9}$

2. $\frac{2}{3} \times \frac{1}{2} =$ _____

- A.
- $\frac{1}{3}$
- B.
- $\frac{3}{5}$
- C.
- $\frac{1}{2}$
- D. 1

3. $\frac{3}{5} \times \frac{5}{7}$ $\frac{3}{7}$

- A. > B. < C. =

4. What is the product of $\frac{4}{5}$ and $\frac{3}{3}$?

- A.
- $\frac{4}{5}$
- B.
- $\frac{7}{8}$
- C. 1 D.
- $\frac{4}{15}$

5. $0.25 \times \frac{8}{9} =$ _____

- A.
- $\frac{1}{4}$
- B.
- $\frac{2}{3}$
- C.
- $\frac{4}{9}$
- D.
- $\frac{2}{9}$

6. $2 \times \frac{\quad}{7} = \frac{6}{7}$

- A. 2 B. 3 C. 4 D. 1

7. $\frac{2}{3} \times \frac{3}{8} \times \frac{8}{9} =$ _____

- A.
- $\frac{1}{3}$
- B.
- $\frac{2}{9}$
- C.
- $\frac{13}{20}$
- D.
- $\frac{2}{17}$

8. _____ $\times \frac{3}{7} = \frac{2}{7}$

- A.
- $\frac{2}{3}$
- B.
- $\frac{3}{2}$
- C.
- $\frac{1}{7}$
- D.
- $\frac{5}{7}$

9. Study the multiplication area model and fill the missing fraction $\frac{2}{6} \times$ _____

- A. $\frac{3}{6}$ B. 3
C. $\frac{3}{7}$ D. $\frac{6}{7}$

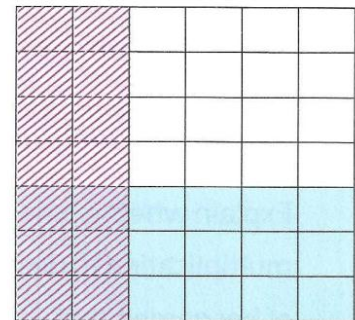

10. Which of the models below shows $\frac{1}{6} \times \frac{1}{3}$? _____

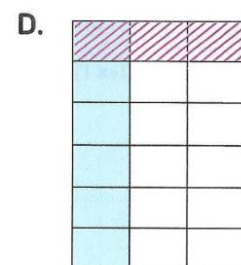
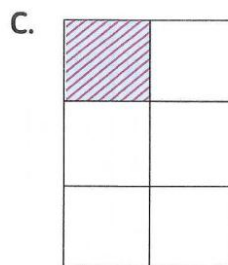
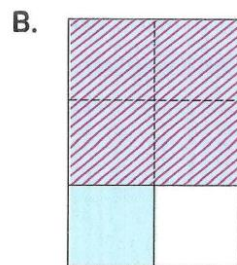
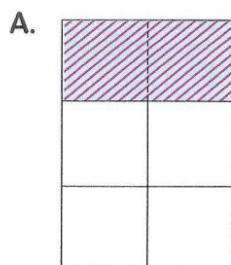



Lesson (4)

Multiplying Fractions and Mixed Numbers

Evaluate each product using the distribution property of multiplication:

a. $3\frac{4}{6} \times \frac{1}{4} =$

b. $2\frac{2}{5} \times \frac{2}{3} =$

c. $5\frac{1}{4} \times \frac{1}{2} =$



Lesson (5)

Multiplying Mixed Numbers Using Improper Fractions

Match:

Mixed Number

a. $3\frac{1}{2}$

b. $4\frac{3}{5}$

c. $2\frac{1}{5}$

d. $6\frac{1}{5}$

e. $5\frac{1}{2}$

f. $2\frac{3}{5}$

g. $1\frac{1}{3}$

h. $2\frac{2}{3}$

Improper Fraction

$\frac{31}{5}$

$\frac{7}{2}$

$\frac{4}{3}$

$\frac{11}{5}$

$\frac{13}{5}$

$\frac{8}{3}$

$\frac{23}{5}$

$\frac{11}{2}$



Rewrite the mixed numbers as improper fractions. Then, simplify before you multiply. Be sure to simplify your answers.

1. $2\frac{1}{4} \times 2\frac{2}{3} =$ _____

2. $1\frac{4}{6} \times 4\frac{2}{5} =$ _____

3. $3\frac{1}{2} \times 1\frac{3}{7} =$ _____

4. $4\frac{2}{7} \times 2\frac{1}{3} =$ _____



Lesson (6)

Story Problems on Multiplying Fractions and Mixed

Ola and Omina were planting flowers in their garden. Ola had 2 bags of flower seeds, but Omina had only $\frac{3}{4}$ of a bag of seeds. Each girl planted $\frac{1}{2}$ of the seeds she had. How many bags of seeds did they plant altogether ?



Planting Seeds



Ayman is taking inventory of his landscaping supplies. He has $2\frac{2}{3}$ bags of fertilizer. Each bag weighs $7\frac{1}{2}$ kilograms. He writes that there are $21\frac{3}{8}$ kg of fertilizer in all. Is Ayman correct ? Explain your thinking.



Fertilizer



Homework

Evaluate each product using the distribution property of multiplication:

a. $\frac{3}{4} \times 2\frac{1}{5} =$

b. $\frac{1}{8} \times 3\frac{2}{5} =$

c. $2\frac{4}{7} \times \frac{5}{8} =$



Rewrite the mixed numbers as improper fractions. Then, simplify before you multiply. Be sure to simplify your answers.

1. $1\frac{1}{3} \times \frac{3}{8} =$ _____

2. $3\frac{1}{3} \times 5\frac{2}{5} =$ _____

3. $6\frac{2}{7} \times 2\frac{6}{11} =$ _____

4. $11\frac{1}{5} \times 4\frac{3}{8} =$ _____



Aya purchased a bag of tomatoes from the market that has a mass of $2\frac{1}{3}$ kilograms. Her brother, Ameen, purchased a bag of potatoes that has a mass $1\frac{1}{2}$ times more than Aya's bag of tomatoes. What is the mass of Ameen's bag of potatoes ?



Nada is making spaghetti sauce.

The recipe calls for $1\frac{3}{4}$ cups of water,
she wants to make $4\frac{1}{2}$ times th recipe.

How much water should she use ?



Moustafa is harvesting sugarcane.

He can harvest $3\frac{3}{4}$ kilograms of sugarcane
in 1 hour. If he plans to work for $2\frac{1}{2}$ hours,

How much sugarcane will he harvest ?



sugarcane



Seif bought 4 bags of soil for his garden.

Each bag has a mass of $3\frac{1}{3}$ kilograms. If he only used $3\frac{3}{4}$ bags of soil,

How many kilograms did he use ?



Concept (9-2)

Lesson (7)

Convert Improper Fraction to Mixed Number

Complete:

- $16 \div 7 = 2 \frac{\quad}{7}$
- The quotient of $8 \div 5 = \text{————}$
- $17 \div 5 = \text{————}$ [as a mixed number]
- $34 \div 5 = 6 + \text{————}$
- Nora divides 6 hours equally to study 4 subjects, then the number of hours for each subject is ———— hours.

Expression	Quotient
$6 \div 5$	$\frac{6}{5} = 1\frac{1}{5}$
$8 \div 5$	
$4 \div 3$	
$5 \div 4$	

Divide 3 pizzas among 5 persons equally,
what is the share of each person?



If you want to distribute 22 liters of oil in 6 small bottles equally,
find the volume of oil in each bottles?





Lesson (8)

Dividing Unit Fractions by Whole Numbers

1. $\frac{1}{3} \div 5 =$ _____

2. $\frac{1}{2} \div 3 =$ _____

3. $\frac{1}{3} \div 2 =$ _____

4. $\frac{1}{3} \div 4 =$ _____



Write the missing number in each equation:

1. $\frac{1}{3} \div a = \frac{1}{12}$ $\frac{1}{3} \times b = \frac{1}{12}$ $a =$ _____ $b =$ _____

2. $\frac{1}{4} \div c = \frac{1}{20}$ $\frac{1}{4} \times d = \frac{1}{20}$ $c =$ _____ $d =$ _____

3. $\frac{1}{5} \div e = \frac{1}{30}$ $\frac{1}{5} \times f = \frac{1}{30}$ $e =$ _____ $f =$ _____

4. $\frac{1}{8} \div g = \frac{1}{24}$ $\frac{1}{8} \times h = \frac{1}{24}$ $g =$ _____ $h =$ _____



Lesson (9)

Dividing Whole Numbers by Unit Fractions

Find the missing value that makes each statement true:

1. $\frac{1}{3} \times \underline{\hspace{1cm}} = 1$

4. $\frac{1}{4} \times \underline{\hspace{1cm}} = 1$

2. $\frac{1}{3} \times \underline{\hspace{1cm}} = 2$

5. $\frac{1}{4} \times \underline{\hspace{1cm}} = 2$

3. $\frac{1}{3} \times \underline{\hspace{1cm}} = 3$

6. $\frac{1}{4} \times \underline{\hspace{1cm}} = 3$





Find the quotient:

1. $4 \div \frac{1}{3}$

5. $3 \div \frac{1}{4}$

2. $3 \div \frac{1}{5}$

6. $4 \div \frac{1}{5}$

3. $5 \div \frac{1}{2}$

7. $8 \div \frac{1}{2}$

4. $2 \div \frac{1}{4}$

8. $6 \div \frac{1}{3}$



Write the missing number in each equation:

1. $5 \div a = 15$

$5 \times b = 15$

$a = \underline{\hspace{2cm}}$

$b = \underline{\hspace{2cm}}$

2. $8 \div c = 32$

$8 \times d = 32$

$c = \underline{\hspace{2cm}}$

$d = \underline{\hspace{2cm}}$

3. $3 \times f = 6$

$3 \div g = 6$

$f = \underline{\hspace{2cm}}$

$g = \underline{\hspace{2cm}}$



Answer the following questions.

a. How many fifths are there in 8 ?

b. How many sixths are there in 10 ?



Lesson (10)

Story Problems Involving Division of a Whole by a Unit

1. If a turtle can crawl $\frac{1}{2}$ kilometers per hour, how many hours would it take for the turtle to travel 8 km?

Choose: $\frac{1}{2} \div 8$ or $8 \div \frac{1}{2}$





2. A teacher wants to give $\frac{1}{8}$ of a box of pencils to each student. She has 5 boxes of pencils. To how many students will she be able to give pencils?

Choose: $\frac{1}{8} \div 5$ or $5 \div \frac{1}{8}$



Homework

Choose the correct answer:

1. $12 \div 5$ equals each of the following except _____

A. $\frac{5}{12}$ B. $\frac{12}{5}$
C. $2\frac{2}{5}$ D. $2 + \frac{2}{5}$

2. The missing fraction on the opposite division algorithm is _____

A. $\frac{4}{14}$ B. $\frac{4}{5}$
C. $\frac{5}{4}$ D. $\frac{7}{2}$

$$\begin{array}{r} 2 \text{ ---} \\ \text{---} \\ 5 \overline{) 14} \\ \underline{- 10} \\ 4 \end{array}$$

3. If we divide 7 oranges among 5 persons, then each person has _____ orange.

A. $\frac{5}{7}$ B. $1\frac{1}{5}$
C. $2\frac{1}{5}$ D. $1\frac{2}{5}$

4. $6\frac{1}{2} = \text{---} \div 2$

A. 11 B. 12
C. 13 D. 14

5. All the following expressions equal each other except _____

A. $22 \div 7$ B. $7 \div 22$
C. $3\frac{1}{7}$ D. $\frac{22}{7}$

6. If Sandy bought 5 kg of meat and wanted to divided it into 4 equally meals, then the number of kilograms in each meal = _____ kg

A. $1\frac{1}{2}$ B. $1\frac{1}{4}$
C. $1\frac{3}{4}$ D. $1\frac{1}{8}$

7. $12 \div 8 = 1\frac{\text{---}}{\text{---}}$

A. 2 B. 3
C. 4 D. 5

8. $14 \div 5 = \text{---} + 2$

A. $\frac{2}{5}$ B. $\frac{3}{5}$
C. $\frac{4}{5}$ D. $\frac{1}{5}$





Shehab has 6 houseplants. It took him 45 minutes to replant them. How long did it take him to replant each one?



The flower shop received 8 equal-sized bundles of chrysanthemums and 10 vases. If the bundles are divided equally among 10 vases, what part of a bundle will each vase get?



5. $\frac{1}{2} \div 7 =$ _____

6. $\frac{1}{8} \div 2 =$ _____

7. $\frac{1}{6} \div 3 =$ _____

8. $\frac{1}{5} \div 5 =$ _____



Write the missing number in each equation:

5. $\frac{1}{2} \times j = \frac{1}{14}$ $\frac{1}{2} \div k = \frac{1}{14}$ $j =$ _____ $k =$ _____

6. $\frac{1}{7} \times m = \frac{1}{21}$ $\frac{1}{7} \div n = \frac{1}{21}$ $m =$ _____ $n =$ _____

7. $\frac{1}{6} \div p = \frac{1}{12}$ $\frac{1}{6} \times q = \frac{1}{12}$ $p =$ _____ $q =$ _____

8. $\frac{1}{10} \times r = \frac{1}{40}$ $\frac{1}{10} \div s = \frac{1}{40}$ $r =$ _____ $s =$ _____





Write the missing number in each equation:

5. $8 \times k = 24$ $8 \div m = 24$ $k = \underline{\hspace{2cm}}$ $m = \underline{\hspace{2cm}}$

6. $7 \div n = 35$ $7 \times p = 35$ $n = \underline{\hspace{2cm}}$ $p = \underline{\hspace{2cm}}$



4. Afaf and Adel pulled up weeds in $\frac{1}{6}$ of the garden's area. If they divided the weeding equally, what total area of the garden did Afaf weed?

Choose: $\frac{1}{6} \div 2$ or $2 \div \frac{1}{6}$



5. A toddler eats $\frac{1}{3}$ of a piece of bread each day for breakfast. If the loaf of bread contains 12 pieces, how many days of breakfast will the loaf of bread provide?

Choose: $\frac{1}{3} \div 12$ or $12 \div \frac{1}{3}$



6. A computer takes $\frac{1}{200}$ of a second to complete a math problem. How many math problems can the computer answer in 120 seconds?

Choose: $\frac{1}{200} \div 120$ or $120 \div \frac{1}{200}$



Answer the following questions.

- a. How many halves are there in 7? b. How many quarters are there in 6?





Unit (9) Assessment

[1] Choose the correct answer:

a. $5 \times \frac{3}{7}$ ○ $4\frac{3}{7}$

- A. < B. > C. =

b. $\frac{1}{3}$ of 12 = _____

- A. 4 B. 3 C. 12 D. 8

c. How many fifths are there in 7?

- A. $5 \div 7$ B. 5×7 C. $5 + 7$ D. $7 - 5$

d. $0.25 \times \frac{6}{7} =$ _____

- A. $\frac{1}{14}$ B. $\frac{1}{7}$ C. $\frac{3}{14}$ D. $\frac{2}{7}$

e. The opposite model represents _____

- A. $\frac{2}{5} \times \frac{7}{6}$ B. $\frac{2}{7} \times \frac{5}{6}$
C. $\frac{2}{5} \times \frac{3}{7}$ D. $\frac{3}{5} \times \frac{6}{7}$

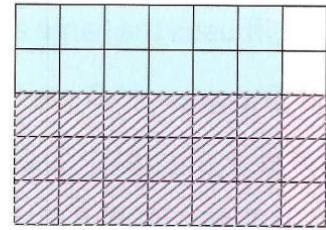

f. $2\frac{2}{3} \times \frac{3}{7} =$ _____

- A. $\frac{3}{7}$ B. $\frac{5}{7}$ C. $\frac{5}{21}$ D. $\frac{8}{7}$

g. $7 \div \frac{1}{4} =$ _____

- A. 28 B. $\frac{1}{28}$ C. $\frac{4}{7}$ D. $\frac{7}{4}$



[2] Complete:

a. $\frac{3}{\quad} \times \frac{5}{8} = \frac{15}{56}$

c. $1\frac{3}{7} \times \text{_____} = 1$

e. $\frac{1}{2} \times \frac{2}{3} \times \frac{3}{4} \times \frac{4}{5} \times \frac{5}{6} \times \frac{6}{7} =$ _____

g. $\frac{1}{3} \div 3 =$ _____

b. $5 \div b = 15$, then $b =$ _____

d. $34 \div 5 = 6 +$ _____

f. If $\frac{1}{3} \div a = \frac{1}{12}$, then $a =$ _____

h. $2\frac{1}{5} \times 2 =$ _____

[3] Choose the correct answer:

- a. If $\frac{1}{3} \div a = \frac{1}{12}$, then a = _____
 A. 4 B. $\frac{1}{4}$ C. $\frac{4}{3}$ D. 36
- b. If $\frac{6}{23} \times a = \left(\frac{6}{23} \times 2\right) + \left(\frac{6}{23} \times \frac{1}{2}\right)$, then a = _____
 A. $1\frac{1}{2}$ B. 2 C. $2\frac{1}{2}$ D. 3
- c. If $8 \div a = 40$, then a = _____
 A. 5 B. $\frac{1}{5}$ C. $\frac{9}{40}$ D. 40
- d. $5 \times \frac{1}{5}$ ○ $5 \div \frac{1}{5}$
 A. < B. = C. >
- e. $2\frac{1}{3} \times 1\frac{2}{7} =$ _____
 A. 3 B. 4 C. 5 D. $2\frac{3}{21}$
- f. $\frac{1}{4} \times m = \frac{1}{20}$, then m = _____
 A. 5 B. $\frac{1}{5}$ C. 10 D. $\frac{1}{10}$
- g. $\frac{5}{3} \times 21 \times \frac{2}{7} =$ _____
 A. $\frac{24}{35}$ B. $\frac{21}{21}$ C. 1 D. 10

**[4] Answer the following:**

- a. Sandy eats $\frac{1}{3}$ of a piece of bread each day for breakfast.

If the loaf of bread contains 9 pieces.

How many days of breakfast will the loaf of bread provide ?



- b. Mariam is reading a chapter book. She can usually read $7\frac{1}{3}$ pages in one hour. If she plans to read for two hours and 15 minutes.

How many pages will she read ?



- c. A teacher wants to give $\frac{1}{4}$ of a box pencils to each student. He has 6 boxes of pencils. To how many students will he be able to give pencils ?





UNIT

10

Theme 4 | Applications of Geometry
and Measurement

Unit 10
Two-
Dimensional
Plane
Figures and
Coordinate
Planes



Photo Credit: Vithornya/Shutterstock.com





Concept (10-1)

Lesson (1)

Classifying of Geometric Shapes

Sketch a quick image representing each of the given vocabulary term:

Parallel lines	Intersecting lines	Perpendicular lines	Acute angle
Obtuse angle	Right angle	Straight angle	A shape with a line of symmetry
A ray	A polygon	A quadrilateral	A parallelogram



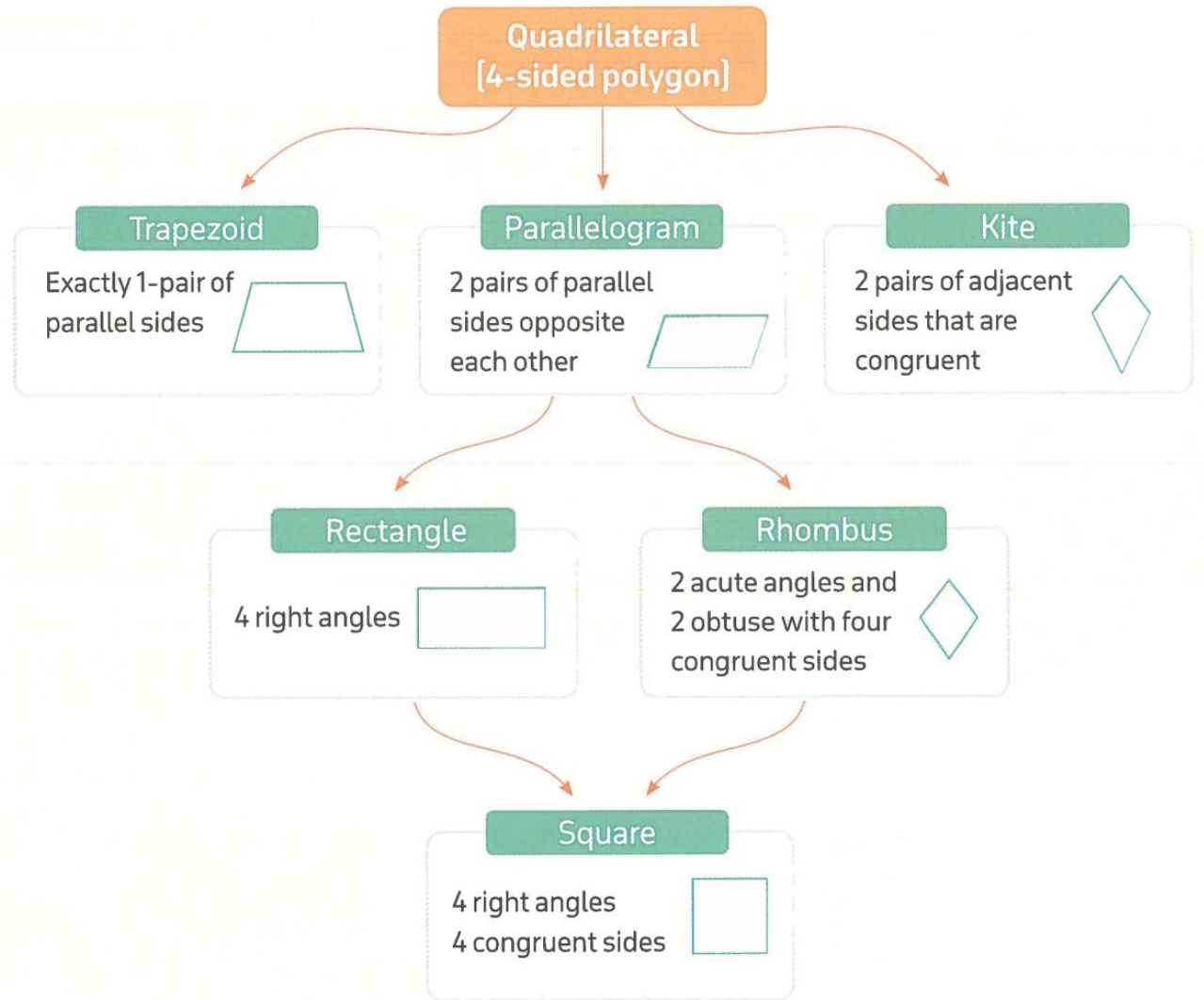

1. Join each figure to its name.



- Rectangle
1
- Trapezium
2
- Triangle
3
- Rhombus
4
- Square
5
- Parallelogram
6





Lesson (2)

Tricky Triangles

Label each triangle. In each angle, place A for acute, O for obtuse and R for right:

1.

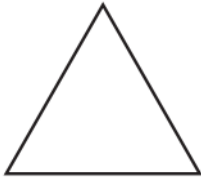

2.

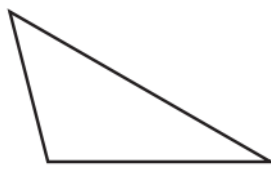

3.



4.



Using the dot paper, can you draw?

- 1- A triangle with two right angles?
- 2- A triangle with two obtuse angles?

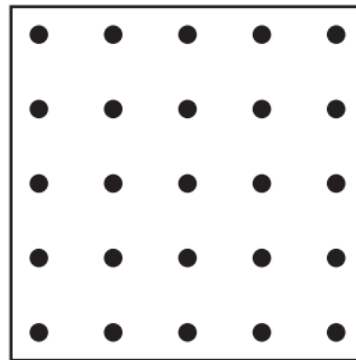
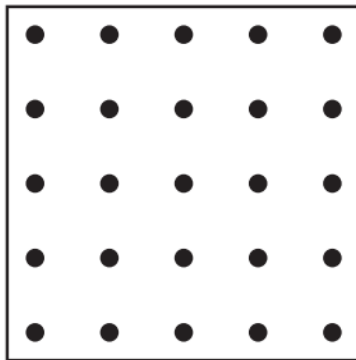

Measure the length of each side. Record your measurements in cm:

1.

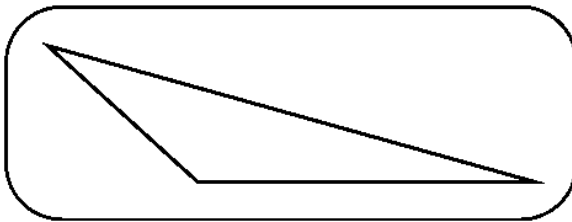

3.

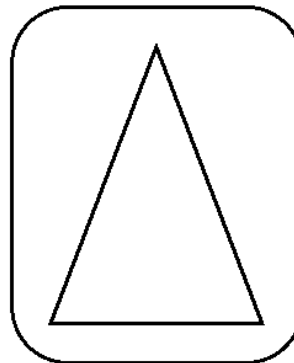

2.

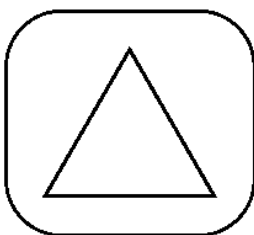

4.

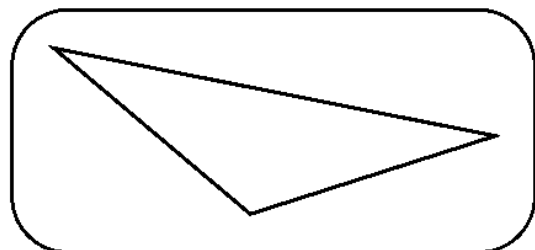



Select the best name for each triangle based on its properties:

1.

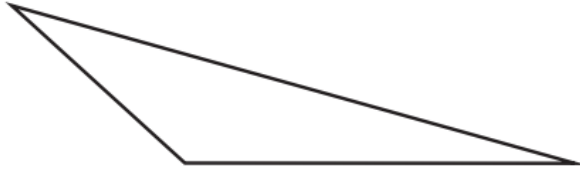

Which two types of triangles are shown?

- | | |
|-------------------------|--------------------|
| A. scalene triangle | D. right triangle |
| B. isosceles triangle | E. acute triangle |
| C. equilateral triangle | F. obtuse triangle |

2.

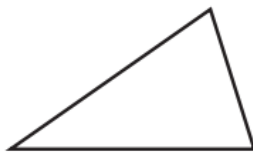

Which two types of triangles are shown?

- | | |
|-------------------------|--------------------|
| A. scalene triangle | D. right triangle |
| B. isosceles triangle | E. acute triangle |
| C. equilateral triangle | F. obtuse triangle |

3.



Which two types of triangles are shown?

- | | |
|-------------------------|--------------------|
| A. scalene triangle | D. right triangle |
| B. isosceles triangle | E. acute triangle |
| C. equilateral triangle | F. obtuse triangle |





Determine the type of each of the following triangles given the measures of their angles.

- a. $m(\angle E) = 30^\circ$, $m(\angle F) = 90^\circ$ and $m(\angle G) = 60^\circ$ " _____ -angled triangle"
- b. $m(\angle I) = 30^\circ$, $m(\angle J) = 40^\circ$ and $m(\angle K) = 110^\circ$ " _____ -angled triangle"
- c. $m(\angle S) = 51^\circ$, $m(\angle T) = 67^\circ$ and $m(\angle U) = 62^\circ$ " _____ -angled triangle"
- d. $m(\angle L) = 32^\circ$, $m(\angle N) = 58^\circ$ and $m(\angle M) = 90^\circ$ " _____ -angled triangle"
- e. $m(\angle X) = 46^\circ$, $m(\angle Y) = 38^\circ$ and $m(\angle Z) = 96^\circ$ " _____ -angled triangle"
- f. $m(\angle H) = m(\angle B) = 70^\circ$ and $m(\angle A) = 40^\circ$ " _____ -angled triangle"
- g. $m(\angle A) = m(\angle B) = 45^\circ$ and $\angle C$ is a right angle. " _____ -angled triangle"



Determine the type of the triangles according to their side lengths using the following data.

- a. $AB = 6.5$ cm , $BC = 7$ cm and $CA = 6.5$ cm " _____ triangle"
- b. $XY = 4.5$ cm , $YZ = 8$ cm and $ZX = 5.5$ cm " _____ triangle"
- c. $NO = 4.5$ cm , $OR = 4.5$ cm and $RN = 4.5$ cm " _____ triangle"
- d. $MA = AY = 9$ cm and $YM = 10$ cm " _____ triangle"
- e. $AM = 10$ cm , $MR = 7$ cm and $RA = \frac{1}{2}AM$ " _____ triangle"



Homework

Write the name that best describes each figure.

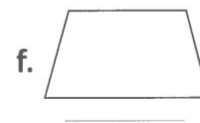
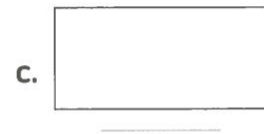
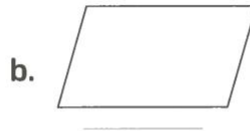
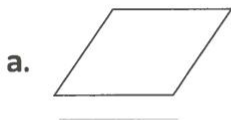



1. Write the type of each angle.

a.

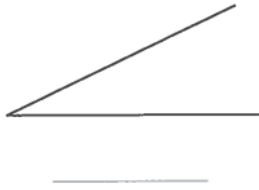

b.



c.



2. Write the relation between 2- straight lines.

a.

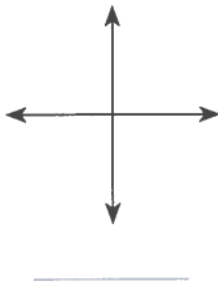

b.



c.

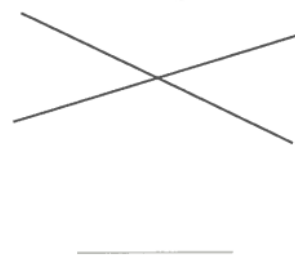

Choose the correct answer:

1. The measure of right angle = _____^o

A. 40

B. 60

C. 120

D. 90

2. The measure of an acute angle the measure of an obtuse angle.

A. <

B. >

C. =

3. The pentagon has _____ side[s].

A. 1

B. 2

C. 3

D. 5

4. The polygon which has four sides is called _____

A. triangle

B. hexagon

C. pentagon

D. quadrilateral

5. The square has _____ axes of symmetry.

A. 1

B. 2

C. 3

D. 4





Use the list of quadrilaterals to fill in the chart:

Rectangle – Parallelogram – Rhombus – Square – Trapezium – Kite

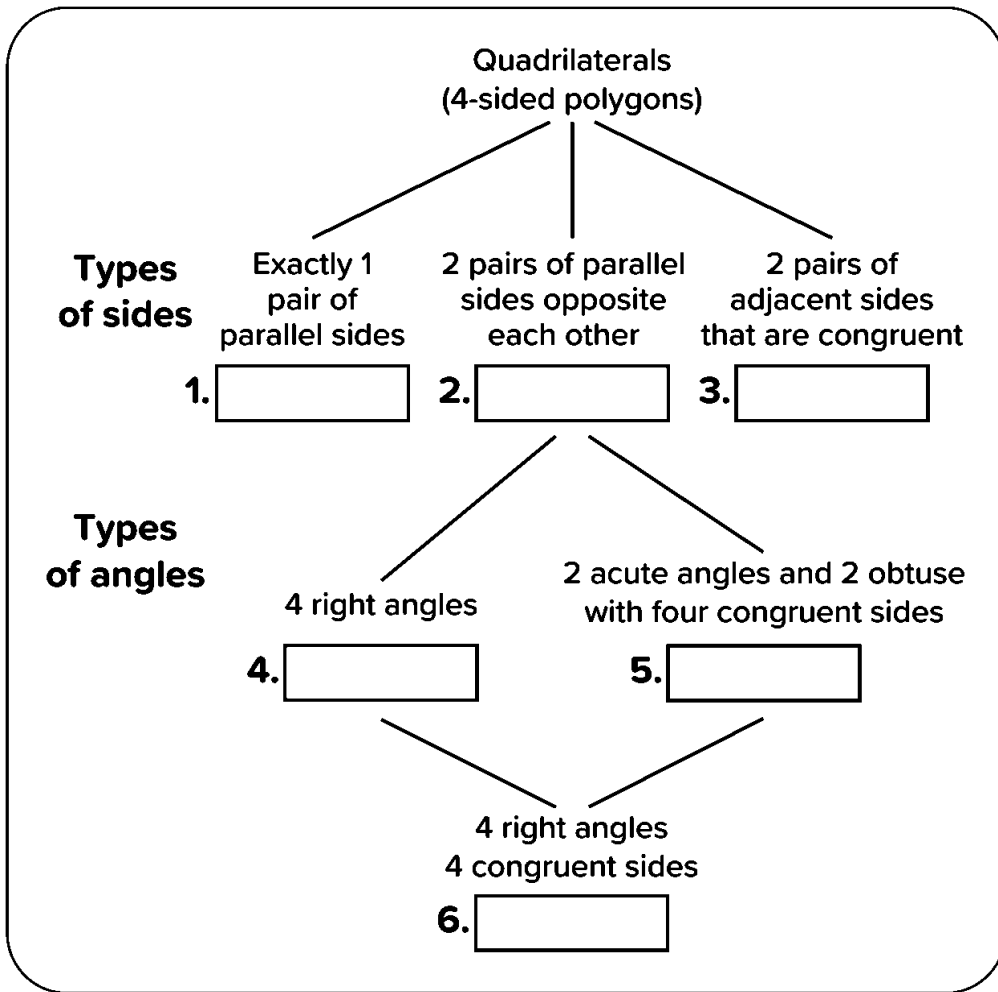

1. Classify each triangle as equilateral, isosceles, or scalene.

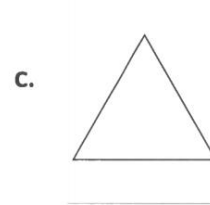
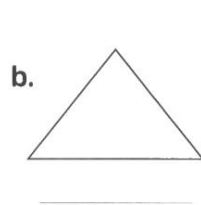
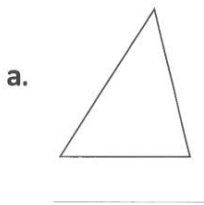

2. Classify each triangle as acute, right, or obtuse.

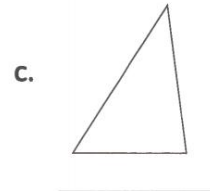
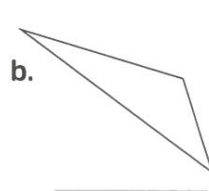
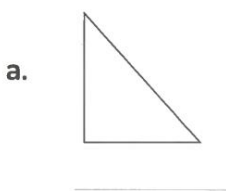



Choose the correct answer:

- If the side lengths of a triangle are different, then the triangle is called _____ triangle.
A. equilateral B. isosceles C. scalene

- The triangle whose side lengths are 7 cm, 4 cm and 7 cm is called _____ triangle.
A. equilateral B. isosceles C. scalene

- The triangle whose side lengths are 8 cm, 6 cm and _____ cm is called scalene triangle.
A. 8 B. 6 C. 7

- 50° , 70° and 60° are the measures of the angles of _____ triangle.
A. an obtuse-angled B. a right-angled C. an acute-angled

- The triangle whose side lengths are _____ is an equilateral triangle.
A. 7 cm, 6 cm, 7 cm B. 5 cm, 5 cm, 5 cm
C. 5 cm, 6 cm, 7 cm D. 3 cm, 4 cm, 4 cm

- The triangle whose measures of angles are 40° , 50° and _____ is right-angled triangle.
A. 50° B. 40° C. 90° D. 180°

- The triangle whose measures of angles are _____ is an obtuse-angled triangle.
A. 30° , 100° , 50° B. 30° , 60° , 90° C. 70° , 80° , 30° D. 50° , 80° , 50°

- The opposite triangle is _____
A. acute B. right
C. obtuse D. equilateral



- The opposite triangle is _____
A. equilateral B. isosceles
C. scalene D. obtuse

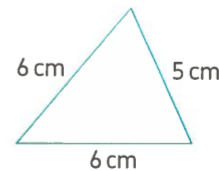

- I am a triangle with only 2 equal sides, the measure of one of my angles is greater than 90° . What kind of triangle am I?
A. isosceles, right B. isosceles, obtuse C. scalene, obtuse D. isosceles, acute





Lesson (3)

Calculating Area with Fractional Dimensions

Find the area of the following rectangles.

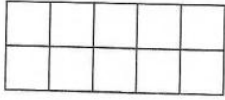

Area = _____ □

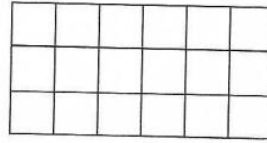

Area = _____ □



Draw a rectangle with an area of 12 square units.

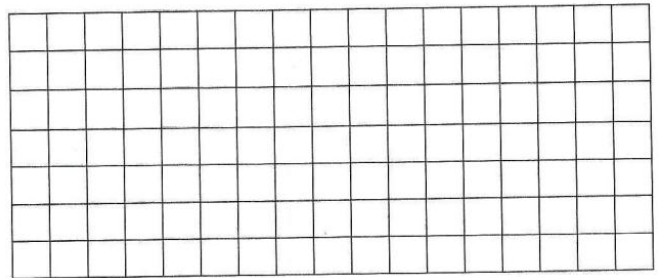

Lesson (4)

Applying the Area Formula

Find area of the following rectangles.

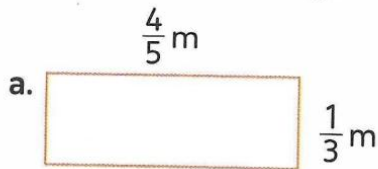

Area = _____

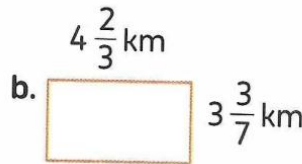

Area = _____



Area = _____



What is the area of the rectangle shown ?

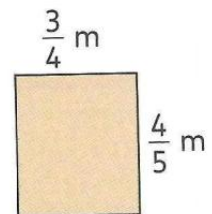



Mostafa draw the opposite rectangle.
Calculate the area of Mostafa's rectangle.

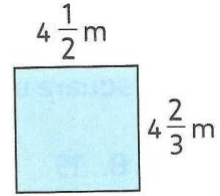

Homework

A mosque has a window that is $\frac{3}{10}$ meter wide and 2 m long. What is the area of the window in square meters ?

Draw a rectangle with an area of 24 square units.

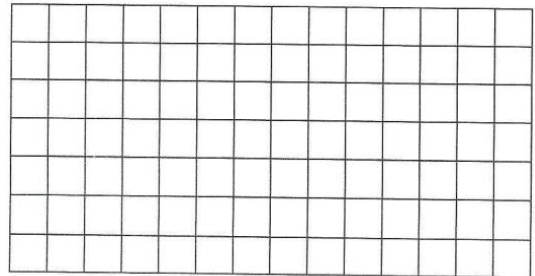

Draw a rectangle with an area of 30 square units.

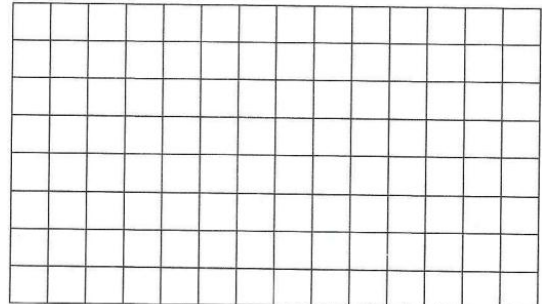



Choose the correct answer:

1. The area of the opposite

rectangle = _____ square units.

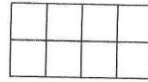

- A. 18 B. 15 C. 8 D. 12

2. The area of rectangle of length $\frac{2}{3}$ cm and width $\frac{2}{5}$ cm is _____ cm^2

- A. $\frac{3}{20}$ B. $\frac{4}{20}$ C. $\frac{4}{9}$ D. $\frac{4}{15}$

3. The area of rectangle of dimensions $5\frac{1}{2}$ meters and $2\frac{1}{2}$ meters is _____

- A. $13\frac{3}{4}$ m B. 8 m C. 8 m^2 D. $13\frac{3}{4} \text{ m}^2$

4. The area of rectangle of dimensions $\frac{2}{5}$ m and $\frac{1}{3}$ m



The area of rectangle of length $\frac{3}{8}$ m and width $\frac{1}{5}$ m

- A. > B. < C. =

5. The area of room of length 6 m and width $3\frac{1}{2}$ m is _____ m^2

- A. 19 B. $9\frac{1}{2}$ C. 21 D. 42

6. Area of rectangle = _____

- A. $L + W$ B. $L \times W$ C. $\frac{L}{W}$ D. $(L + W) \times 2$

7. The area of rectangle of dimensions $3\frac{1}{5}$ cm and $2\frac{1}{2}$ cm is _____

- A. 8 m^2 B. 8 cm^2 C. 8 km^2 D. 8 cm

8. Area of opposite rectangle

= _____ cm^2

$7\frac{1}{4}$ cm

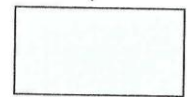

$5\frac{2}{5}$ cm

- A. $25\frac{3}{10}$ B. $40\frac{1}{2}$ C. $12\frac{13}{20}$ D. $39\frac{3}{20}$

9. The area of rectangle with length $\frac{3}{4}$ km and width $\frac{1}{3}$ km is _____

- A. $\frac{1}{4}$ km B. $\frac{1}{4} \text{ km}^2$ C. $\frac{13}{12}$ km D. $\frac{1}{2} \text{ km}^2$

10. A mosque has a window that is $\frac{3}{5}$ meter wide and $1\frac{1}{2}$ meters long. What is the area of the window in square meters ?

- A. $\frac{9}{10} \text{ m}^2$ B. $2\frac{1}{2} \text{ m}^2$ C. $2\frac{1}{10} \text{ m}^2$ D. $10\frac{1}{2} \text{ m}^2$



Concept (10-2)

Lesson (5)

Explore the Coordinates Plane

➔ The coordinate plane

The coordinate plane is the plane determined by a horizontal line, called the **x-axis**, and a vertical line, called the **y-axis**, intersecting at a point, called **the origin**. It is labeled as "O"

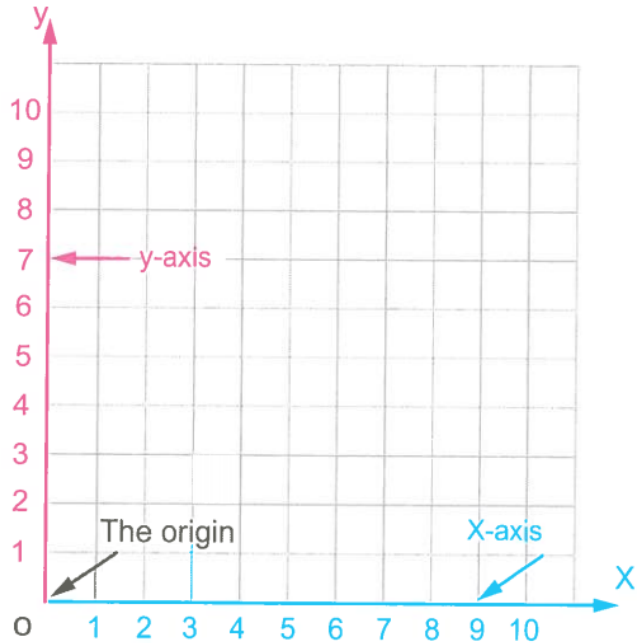

➔ The ordered pair

The ordered pair is a pair of numbers used to locate any point on a coordinate plane. Ordered pairs are written left to right (x, y)

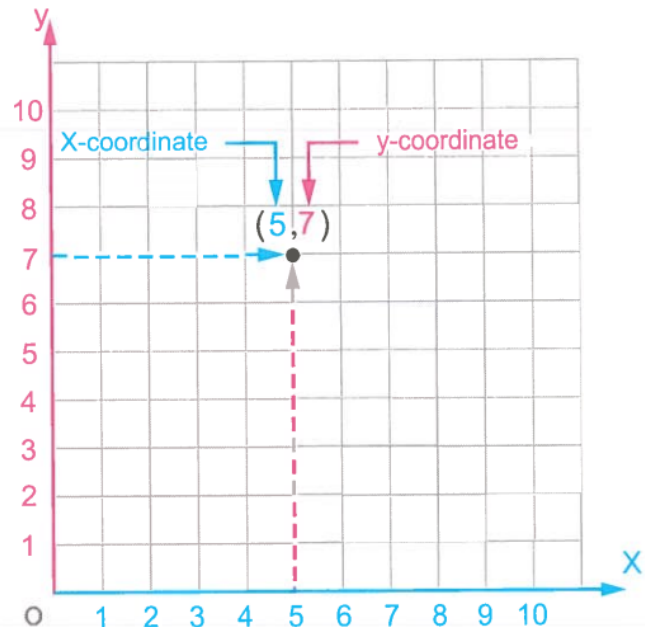



Lesson (6) Plotting Points on a Coordinate Plane

Using the following graph, answer [a] , [b] and [c]

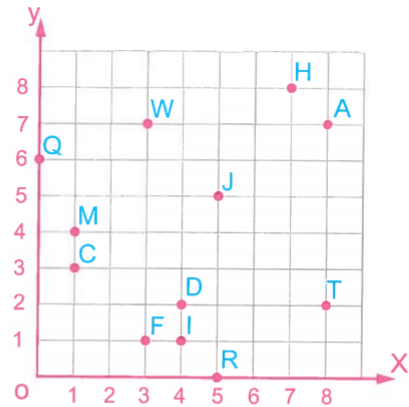

a. What is the name of each of the following points ?

- | | |
|----------|----------|
| 1. (3,1) | 2. (7,8) |
| 3. (1,4) | 4. (5,0) |
| 5. (8,7) | 6. (4,2) |
| 7. (5,5) | 8. (1,3) |

b. Write the ordered pair for each of the following points :

- | | |
|------|------|
| 1. A | 2. T |
| 3. W | 4. I |
| 5. Q | |

c. Plot the following points on the coordinates grid :

- | | |
|------------|------------|
| 1. B (2,8) | 2. E (0,7) |
| 3. X (6,3) | 4. S (8,5) |
| 5. P (2,1) | 6. G (7,7) |



Plot the points on the coordinate grid.

A (3,5) , B (6,5) , C (6,2) , D (3,2) and connect the points in order.

a. What polygon did you create ?

b. Complete.

- | | |
|-----------------------------------|-----------------------------------|
| • $\overline{AD} \parallel$ _____ | • $\overline{AB} \parallel$ _____ |
| • $\overline{DC} \perp$ _____ | • $\overline{BC} \perp$ _____ |

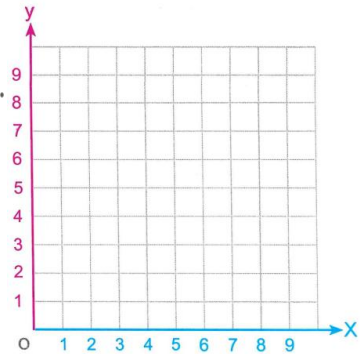

a. Plot the points on the coordinate grid.

- | | |
|---------|---------|
| A (3,2) | B (3,5) |
| C (6,5) | D (6,2) |

b. Connect the points in order.

What polygon did you create ?

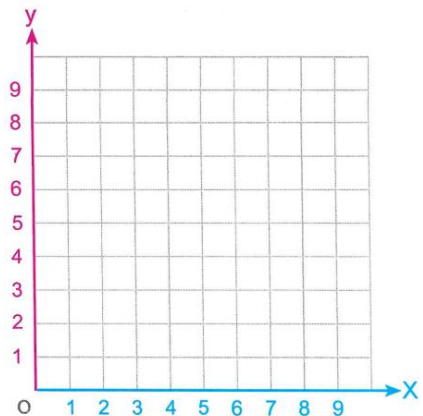



Lesson (7)

Coordinate Designs

On the coordinate plane, plot points F, G, and H to make a figure that is symmetrical along the vertical orange line drawn on the coordinate plane. (Point F should follow point E) Connect point H to point A to close the shape. Then, list the coordinates of F, G and H.

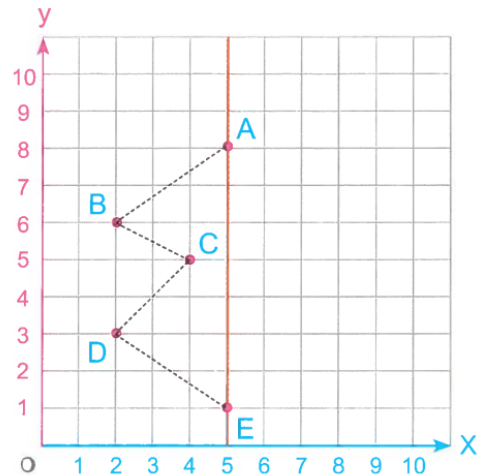

In the opposite coordinate plane :

- a. Graph the figure ABCD where $A(0, 3), B(7, 3), C(7, 5), D(0, 5)$.
- b. What is the name of the figure ABCD ?

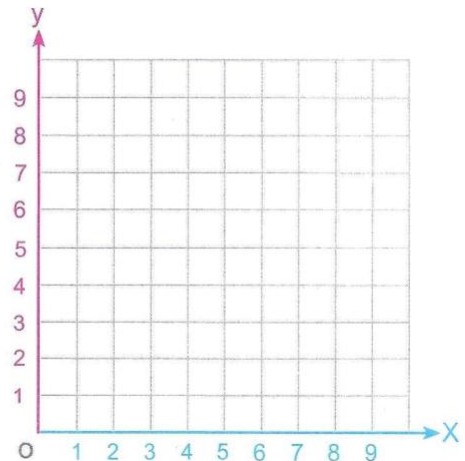

In the opposite coordinate plane :

- a. Graph the figure ABCD where $A(2, 8), B(3, 4), C(8, 4)$ and $D(7, 8)$
- b. What is the name of the figure ABCD ?
- c. What is the length of \overline{AD} ?
- d. $\overline{AD} \parallel$ _____, $\overline{AB} \parallel$ _____

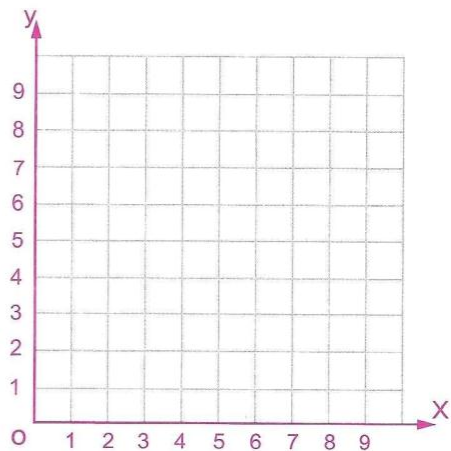



Lesson (8)

Representing Points and Creating Patterns

Extend the following table and identify the pattern of x values and y values.

a.

x values	1	2	3	4	___	___	___
y values	1	2	3	4	___	___	___

b.

x values	10	20	30	40	___	___	___
y values	1	5	9	13	___	___	___

c.

x values	$\frac{1}{2}$	$1\frac{1}{2}$	$2\frac{1}{2}$	$3\frac{1}{2}$	___	___	___
y values	$1\frac{1}{2}$	$2\frac{1}{2}$	$3\frac{1}{2}$	$4\frac{1}{2}$	___	___	___

d.

x values	2	4	6	8	___	___	___
y values	36	33	30	27	___	___	___



Use the pattern to complete the table and represent on the coordinate plane.

x values	1	2	3	4	5	6	7
y values	2	4	6	8	10	___	___

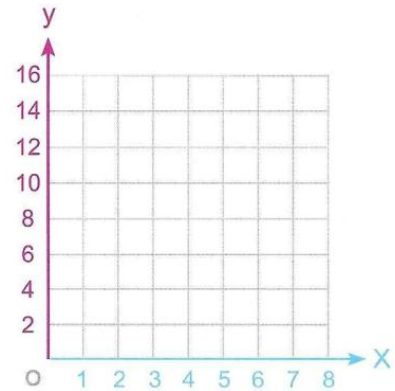



Lesson (9)

Graphing Real-World Data

Ola is selling bags of cookies in her neighborhood to make extra money to buy a new bike. She earns 5 LE for each bag of cookies she sells. Complete the table and then graph the points on the coordinate grid.

Bags of Cookies	Money Earned LE
2	
4	
6	
8	
10	

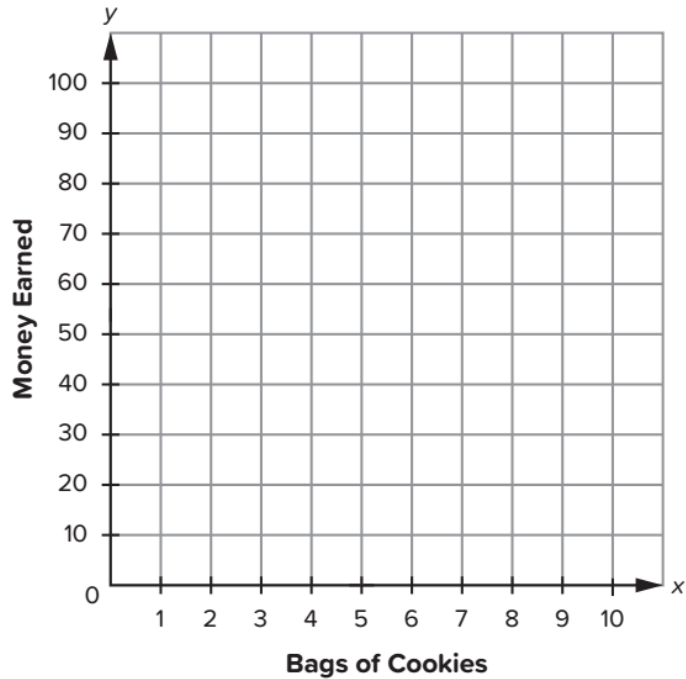

Amgad saves daily an amount of pound three times the amount his sister Amal saves.

- Write a rule represents these information.
- Complete the following table.

Amal saved in L.E. (p)	1	2	—	4	—	8
Amgad saved in L.E. (l)	3	6	9	—	18	—

- Using Amal saved money data as x-coordinates and Amgad saved data as y-coordinates, plot data on the coordinate grid then draw a line to connect the points.

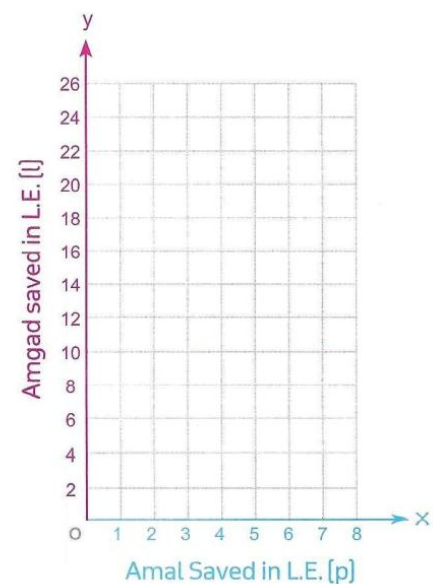



Homework

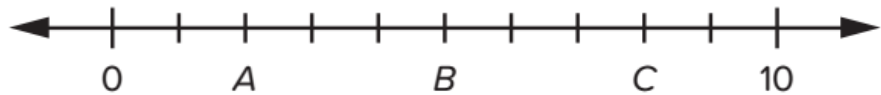

1. What is the value of B?
2. What is the value of A?
3. What is the value of C?



1. What is the value of each space between the hashmarks?
2. What is the value of A?
3. What is the value of B?
4. What is the value of C?
5. What is the value of D?

Use the ordered pairs to fill in the table.

a. (0, 1), (2, 3), (4, 5), (6, 7) and (8, 9)

x values					
y values					

b. (1, 1), (2, 2), (3, 3), (4, 4) and (5, 5)

x values					
y values					



Write the ordered pair of each picture:

 (5, 5)

 _____

 _____

 _____

 _____

 _____

 _____

 _____

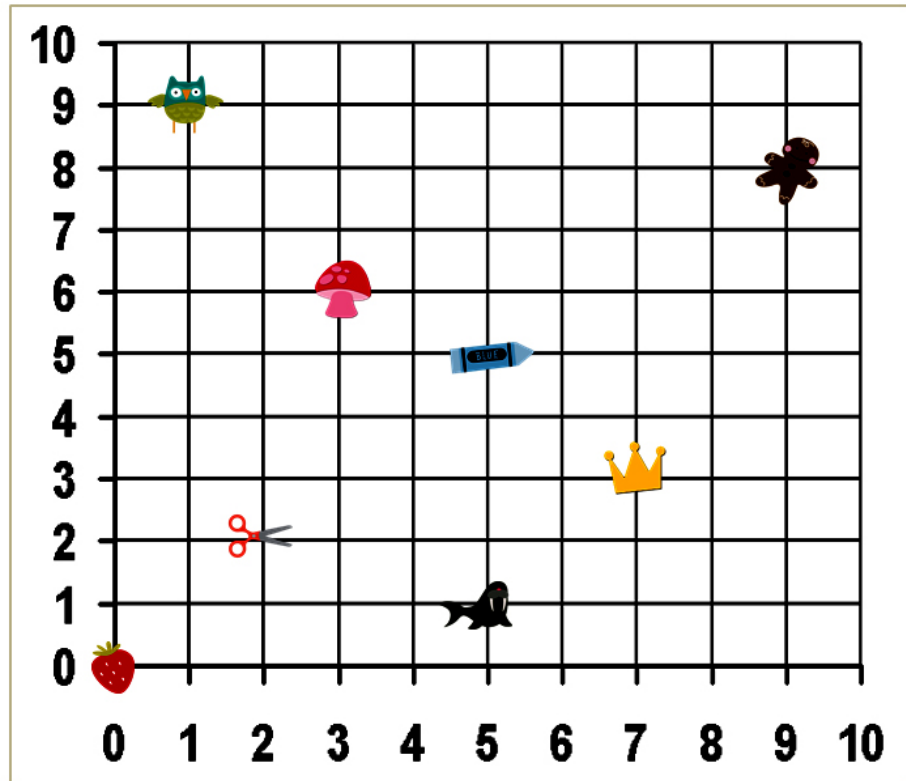

Represent the following tables on the coordinate plane.

x values	1	3	5	7	9	11
y values	5	15	25	—	—	—

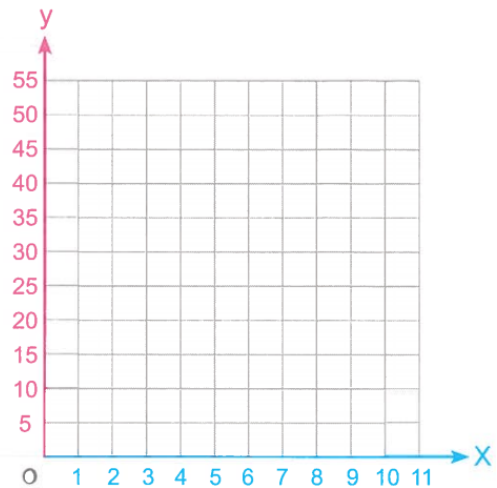



Choose the correct answer:

1. The y-coordinate in ordered pair (1, 3) is _____
- A. 2 B. 3 C. 5 D. 6

2. The first number in an ordered pair is _____
- A. x-coordinate B. x-axis
C. y-coordinate D. y-axis

3. The ordered pairs which represents $\triangle ABC$ are _____

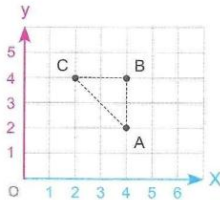

- A. (4, 2), (4, 5), (2, 5)
B. (2, 4), (4, 4), (4, 2)
C. (2, 4), (4, 1), (4, 2)
D. (4, 4), (4, 2), (1, 4)

4. The ordered pairs which represents the rectangle ABCO are _____

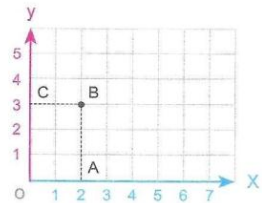

- A. (0, 0), (3, 0), (2, 0), (2, 3)
B. (0, 0), (0, 2), (2, 3), (3, 0)
C. (0, 0), (0, 3), (2, 0), (2, 3)
D. (0, 0), (3, 0), (2, 4), (2, 0)

5. The ordered pair which represents an isosceles right-angled triangle at point B is _____

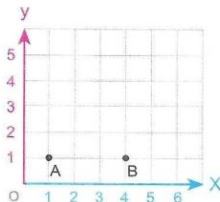

- A. (1, 4) B. (3, 4)
C. (4, 3) D. (4, 4)

6. a. How far is point C from point D ?

- A. 2 B. 3
C. 4 D. 5

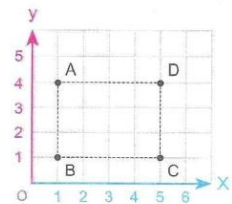

- b. $\overline{AB} \parallel$ _____
- A. \overline{AD} B. \overline{BC}
C. \overline{DC} D. \overline{AC}

- c. $\overline{DC} \perp$ _____
- A. \overline{AC} B. \overline{BC}
C. \overline{BD} D. \overline{AB}

7. Which of the following points located on x-axis? [El Beheira - El Nobarria 23]

- A. (1, 0) B. (0, 1)
C. (1, 1) D. (3, 2)

8. Which of the following points located on y-axis? [Cairo - Shoubra 23]

- A. (1, 0) B. (0, 1) C. (1, 1) D. (3, 0)

9. The origin point = _____

[Suez 23, El Fayoum 23]

- A. (1, 0) B. (0, 0) C. (0, 2) D. (1, 2)





Unit (10) Assessment

[1] Choose the correct answer:

1. The triangle whose side lengths are _____ is an isosceles triangle.

- A. 7 cm , 7 cm , 7 cm B. 5 cm , 7 cm , 5 cm
C. 4 cm , 5 cm , 3 cm D. 8 cm , 6 cm , 9 cm

2. The area of rectangle of length $\frac{2}{3}$ cm and width $\frac{2}{5}$ cm is _____ cm^2

- A. $\frac{3}{20}$ B. $\frac{4}{20}$ C. $\frac{4}{9}$ D. $\frac{4}{15}$

3. The X-coordinate in ordered pair (3 , 4) is _____

- A. 3 B. 4 C. 7 D. 1

4. The value of the missing numbers in the following table is _____

x values	2	3	4	5	6
y values	2	4	6	_____	_____

- A. 7 , 9 B. 8 , 10 C. 6 , 8 D. 10 , 12

5. The polygon which has only one pair of parallel sides is called _____

- A. trapezium B. parallelogram C. rhombus D. square

6. The opposite triangle is _____

- A. right B. acute
C. obtuse D. scalene

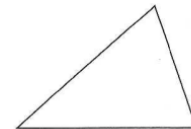

7. The measure of any angle of the square = _____ $^{\circ}$

- A. 60 B. 90 C. 100 D. 180



[2] Complete:

a. The four sides are equal in length in _____ and _____

b. The triangle XYZ is an equilateral triangle whose perimeter is 18 cm

, then XY = _____ cm

c. In the opposite number line :

The value of D is _____





d. In the opposite figure :

The ordered pairs that represent the point A is _____

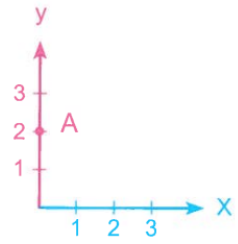

e. Each two opposite sides are parallel

in _____ , _____ , _____ and _____

f. The triangle opposite

is _____ - angled triangle.

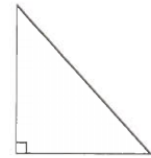

g. The point (0 , 7) lies on _____ - axis.

h. In any triangle, there are two _____ angles at least.



[3] Choose the correct answer:

a. If the area of rectangle is 2 square meters and one of its dimensions is $\frac{1}{2}$ m, then the other dimension is _____

- A. 1 m B. 2 m C. $2\frac{1}{2}$ m D. 4 m

b. ABC is an equilateral triangle. If two side lengths of it are 6.5 cm and 6.5 cm, then the third side is _____ cm.

- A. 13 B. 2.25 C. 6.5 D. 7

c. The hexagon has _____ sides.

- A. 4 B. 5 C. 6 D. 7

d. The y-coordinate in the ordered pair (6.5 , 6.2) is _____

- A. 6.5 B. 6.2 C. 12.7 D. 0.3

e. The area of a square of side length 2.5 cm is _____ cm^2

- A. 6.25 B. 5 C. 10 D. 0.5

f. The subcategories of square and rhombus is _____

- A. 4 right angles B. 4 equal sides
C. 2 acute angles D. 2 obtuse angles

g. Which of the following points located on x-axis ?

- A. (4 , 0) B. (0 , 4) C. (4 , 5) D. (5 , 4)



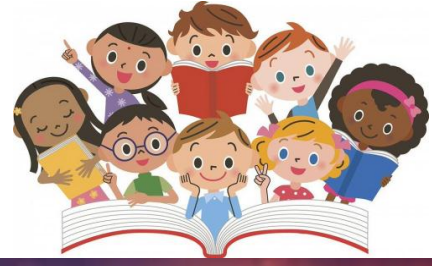

UNIT

11

Theme 4 | Applications of Geometry and Measurement

Unit 11 Volume

Photo credit: Menydia / Shutterstock.com



Concept (11-1)

Lesson (1)

Geometric Shapes around Us

Rectangular prism (Cuboid)

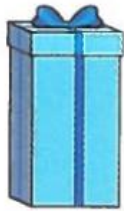

Cube

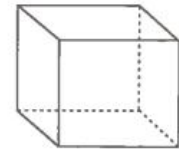

Sphere

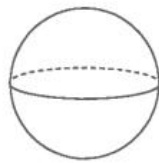

Cone



Cylinder



Square pyramid

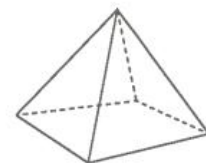
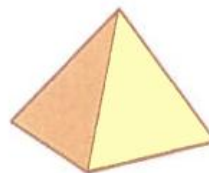

A **face** is a flat surface of a solid figure.

An **edge** is the line segment formed where two faces meet.

A **vertex** is a point where three or more edges meet.

The plural of vertex is vertices.

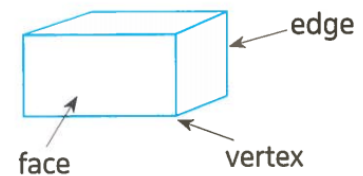



Name the solid figure that each object looks like

a.



b.



c.



d.



e.









f.

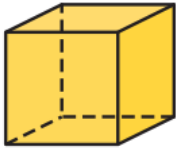



Complete the table:

Attributes of Three-Dimensional Shapes						
	Name	Picture	Face/ Base Shape(s)	Number of Faces/ Bases	Number of Edges	Number of Vertices
1	Cube					
2	Cone					
3	Cylinder					
4	Rectangular Prism					
5	Sphere					
6	Square Pyramid					





Complete:

Write how many faces, edges and vertices are there.



- _____ vertices.
- _____ flat faces.
- _____ edges.

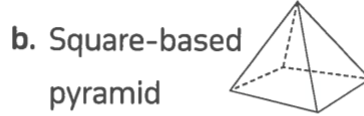

- _____ vertices.
- _____ flat faces.
- _____ edges.



- _____ vertices.
- _____ flat faces.
- _____ edges.



Match:



- ➔ pyramid ➔ sphere ➔ rectangular prism ➔ cube ➔ cone





Lesson (2)

Measuring Volume in Cube Units

Complete:

a.

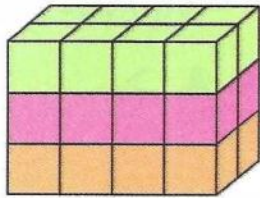

- Number of horizontal layers = _____
- Number of cube[s] in each horizontal layer = _____ cubes.
- Volume = _____ × _____
= _____ cube units

b.

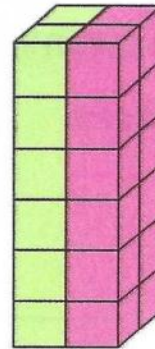

- Number of vertical slices = _____
- Number of cubes in each vertical slices = _____
- Volume = _____ × _____
= _____ cube units



Lesson (3)

Same Volume, Different Shape

1. Number of vertical slices : _____
2. Number of cubes in each vertical slice : _____
3. Volume = _____ × _____ = _____ cm^3

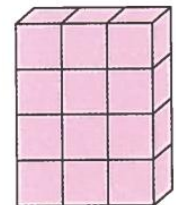

1. Number of vertical slices : _____
2. Number of cubes in each vertical slice : _____
3. Volume = _____ × _____ = _____ cm^3

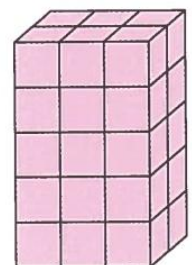



If you cut and fold the opposite net square, then complete.

a. Name of the resulted solid _____

b. Volume of the resulted solid _____

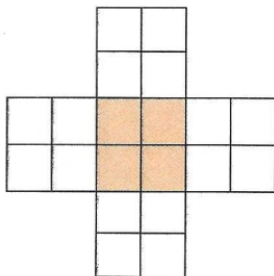
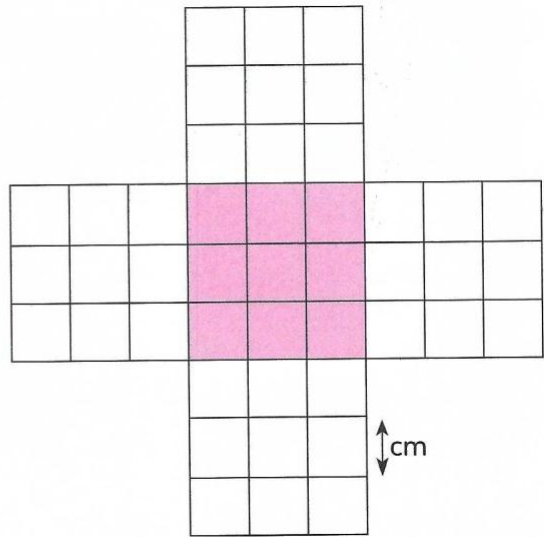

Volume : _____ cubic centimeters.

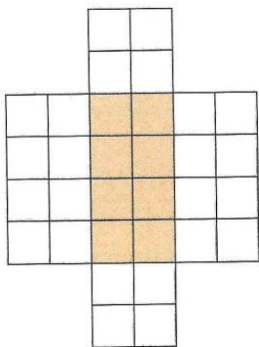

Volume : _____ cubic centimeters.

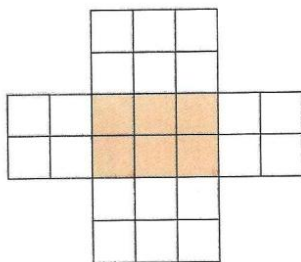

Volume : _____ cubic centimeters.





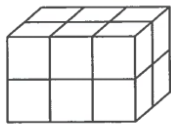

Choose the correct answer:



1. Volume of  is _____ cube units

- A. 8 B. 12 C. 24 D. 10

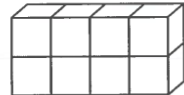
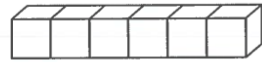
2. Which of the following is of volume 8 cm^3 ?

- A.  B.  C.  D. 

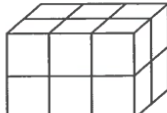
3. Which of the following has different volume ?

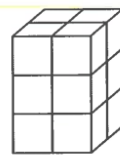
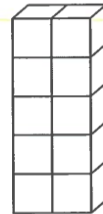
- A.  B.  C.  D. 

4. A cuboid has 3 horizontal layers and 6 cube units in each layer, then its volume = _____ cube units.

- A. 9 B. 18 C. 24 D. 12

5. A cuboid has 2 vertical slices each slice has 4 cm^3 , then its volume = _____ cm^3

- A. 6 B. 4 C. 12 D. 8

6. A box is filled by 4 horizontal layer, each layer contains 8 cube units, then its capacity = _____ cube unit.

- A. 4 B. 12 C. 32 D. 24

7. What solid is formed from folding the net square  ?

- A.  B.  C.  D. 

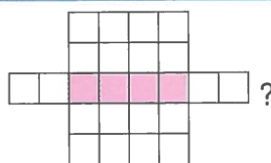
8. What is the volume of the solid formed from folding the net square  ?

- A. 12 B. 4 C. 16 D. 8





Homework

Complete:

Name the solid figure. Then tell the number of faces, edges, and vertices.

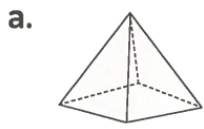

Name : _____
 * _____ faces.
 * _____ edges.
 * _____ vertices.

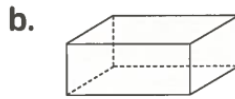

Name : _____
 * _____ faces.
 * _____ edges.
 * _____ vertices.

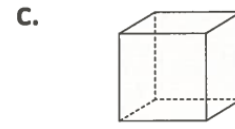

Name : _____
 * _____ faces.
 * _____ edges.
 * _____ vertices.

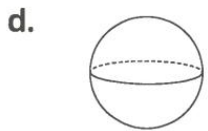

Name : _____
 * _____ flat faces.
 * _____ edges.
 * _____ vertices.



Name : _____
 * _____ flat faces.
 * _____ edges.
 * _____ vertices.

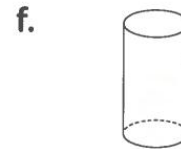

Name : _____
 * _____ flat faces.
 * _____ edges.
 * _____ vertices.



1. Number of horizontal layers : _____
2. Number of cubes in each horizontal layer : _____
3. Volume = _____ × _____ = _____ cm³

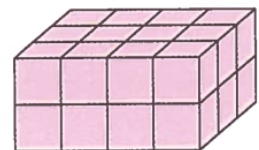

1. Number of horizontal layers : _____
2. Number of cubes in each horizontal layer : _____
3. Volume = _____ × _____ = _____ cm³

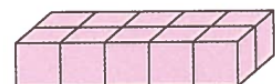



1. Number of horizontal layers : _____

2. Number of cubes in each horizontal layer : _____

3. Volume = _____ x _____ = _____ cm^3

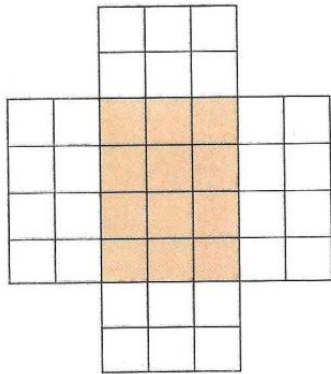
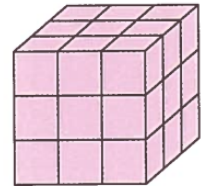

Volume : _____ cubic centimeters.

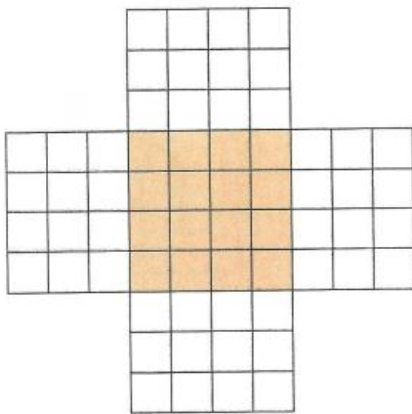

Volume : _____ cubic centimeters.



Match each net square to its suitable solid.

a.

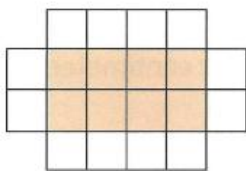

b.

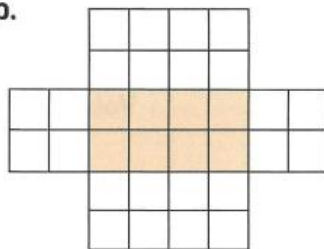

c.

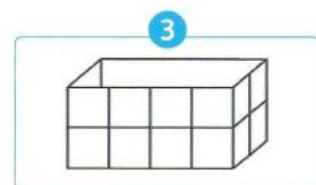
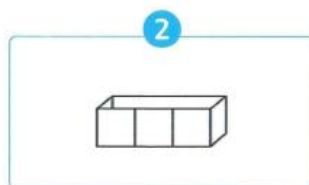
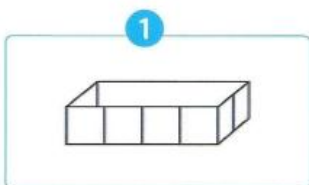
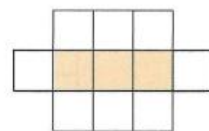



Choose the correct answer:

1. Which of the following is a cube ?

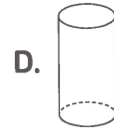
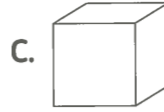
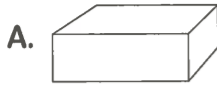

2. Which of the following has 8 vertices ?

A. Sphere

B. Rectangular prism

C. Square-based pyramid

D. Cone

3. In which of the following you can find ?

A. Cube

B. Sphere

C. Rectangular prism

D. Cylinder

4. The solid which has 12 edges, 8 vertices and 6 rectangle faces is _____

A. cube

B. cuboid

C. square base pyramid

D. cylinder

5. has _____ .

A. 4

B. 8

C. 10

D. 2

6. Volume of _____ volume of .

A. >

B. <

C. =

7. The cuboid has _____ edges.

A. 14

B. 8

C. 20

D. 12

8. The pieces of cards can form _____

A. cuboid

B. cube

C. pyramid

D. cylinder





Concept (11-2)

Lesson (4)

Finding a Formula

Label the dimensions of the rectangular prism. Each cube is 1 centimeter on all sides.

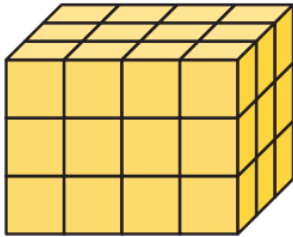

Length: _____ cm

Width: _____ cm

Height: _____ cm



Record the dimensions of the given rectangular prism and then find the volume.

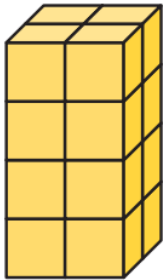

Length: _____ cm

Width: _____ cm

Height: _____ cm

Volume: _____ cm³



Record the dimensions of the rectangular prism and then find the volume.

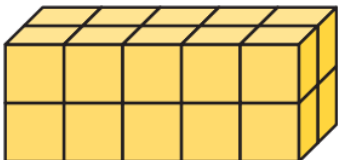

Length: _____ cm

Width: _____ cm

Height: _____ cm

Volume: _____ cm³

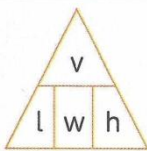

$$v = l \times w \times h$$

$$l = \frac{v}{w \times h}$$

$$w = \frac{v}{l \times h}$$

$$h = \frac{v}{l \times w}$$

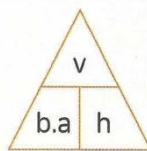

$$v = \text{base area} \times h$$

$$\text{base area} = \frac{v}{h}$$

$$h = \frac{v}{\text{base area}}$$

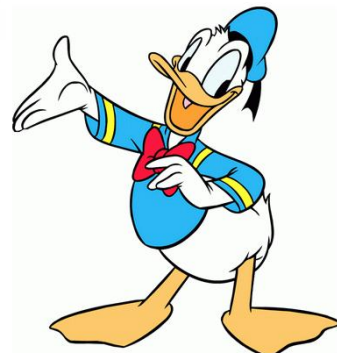



Lesson (5) Using a Formula to Find Volume

Compare the dimensions of the rectangular prisms. Which two prisms have the same volume? Explain how you know.

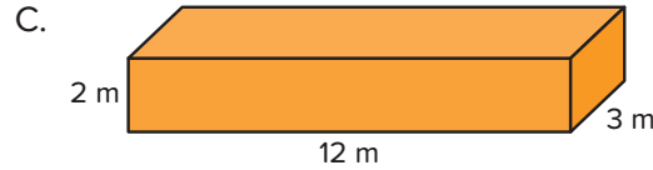
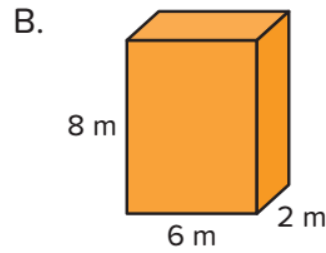
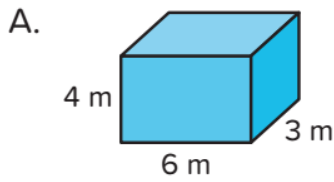

Multiply to find the volume of the prism. Record your equation and the total volume. Be sure to include units.

Equation: _____

Volume: _____

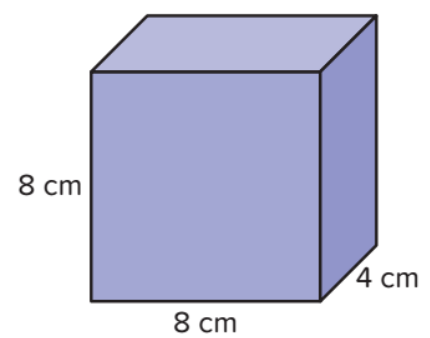

Eman says that prism B has the greatest volume because it has the greatest height. Do you agree or disagree? Explain your thinking.

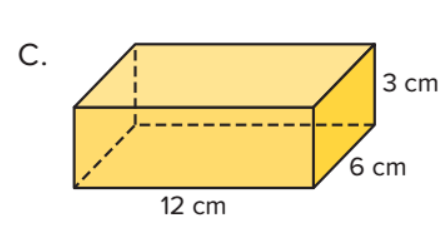
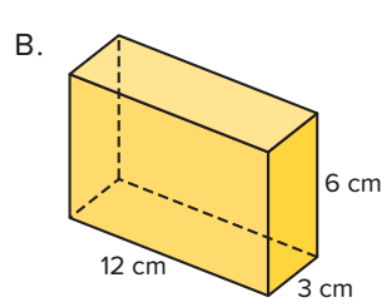
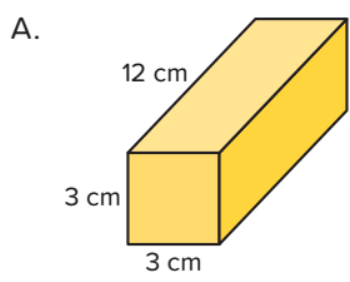



Complete:

a.

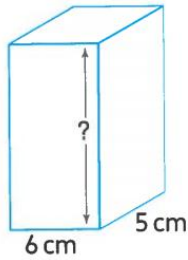

- Volume = 300 cm^3
- Missing dimension = _____ cm

b.

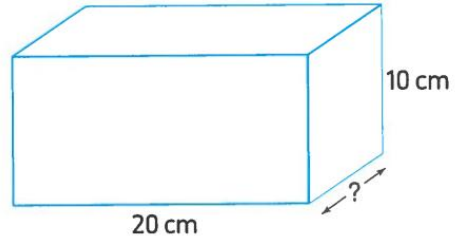

- Volume = $1,200 \text{ cm}^3$
- Missing dimension = _____ cm



Complete:

c.

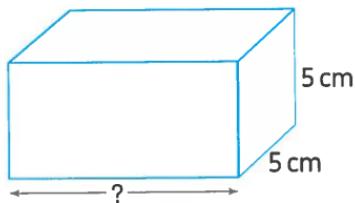

- Volume = 250 cm^3
- Missing dimension = _____ cm

d.

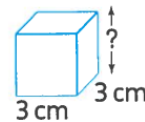

- Volume = 27 cm^3
- Missing dimension = _____ cm



Lesson (6)

Finding the Volume of Compound Shapes

Determine the volume of the given compound shape.

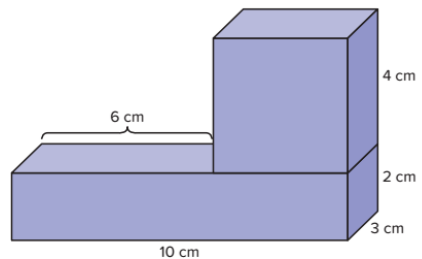

Determine the volume of the given compound shape.

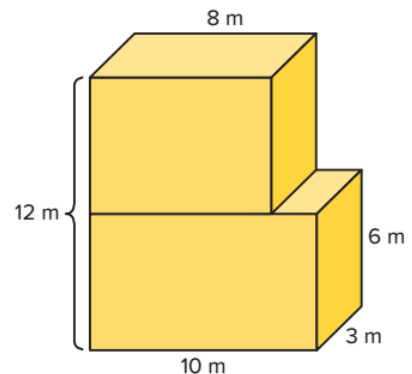

Lesson (7)

Solving Real-World Volume Story Problems

8,100 cm³ of water are poured in a cuboid-shaped vessel with a square base of side length 25 cm. Find the height of water in the vessel.



Osman built a planter box for his backyard. The length of the planter box was 150 centimeters. The width was 90 cm, and the height of the box was 120 cm. Osman poured soil into the box up to the 100 cm height line. What is the volume of the planter box? What is the volume of the soil?



Fares built a small planter box for his window. He planned to fill it to the top with 12,000 cubic centimeters of soil. The base of the planter box measured 40 cm long and 15 cm wide. What should the height of the box be to hold all the soil?



A juice case is in the shape of cuboid, its base is square-shaped of side length 6 cm and its height is 15 cm

Calculate the volume of juice which fills the case completely.



A swimming pool is in the shape of a cuboid, its base is of length 60 meters and its width is 40 meters. Find its depth if 36,000 m³ of water fill this swimming pool completely.





Homework

Record the dimensions of the rectangular prism and then find the volume.

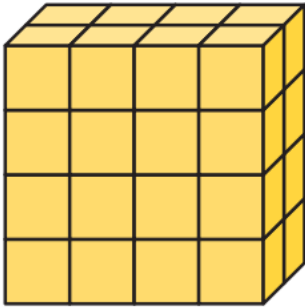

Length: _____ cm

Width: _____ cm

Height: _____ cm

Volume: _____ cm³



Find the volume of each figure:

a.

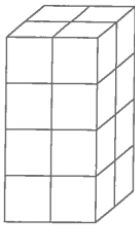

b.

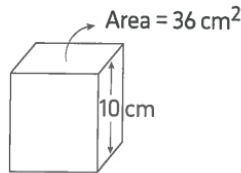

c.

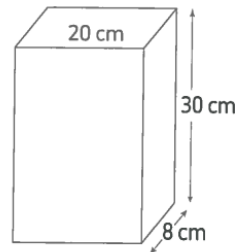

a. _____

b. _____

c. _____



What is the volume of the given compound shape?

a.

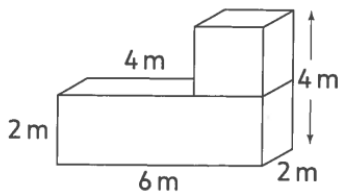

b.

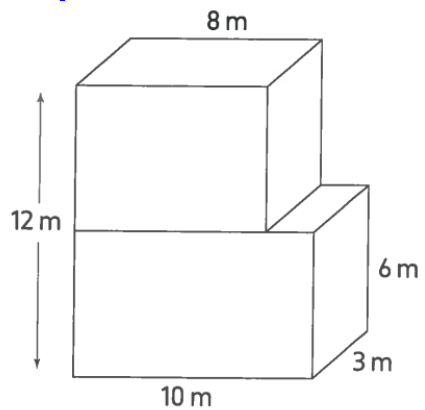



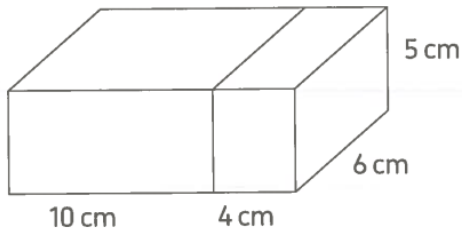

d.

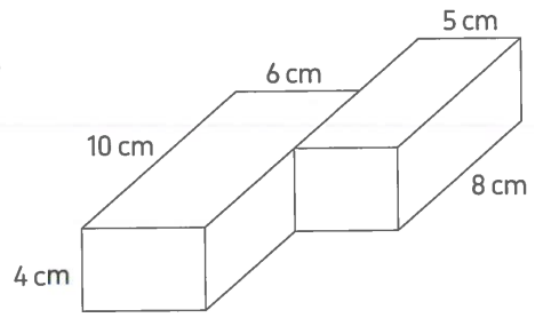



A builder used 100 bricks for building up a wall. If each brick is in the shape of a cuboid of dimensions 25 , 12 and 6 centimeters. Calculate the volume of the wall.



A cuboid-shaped swimming pool has a base of dimensions 60 m and 30 m and its height is 3 m. Water was poured into the pool till its level reached 1 m from the brim of the pool.



Find the volume of water in m^3



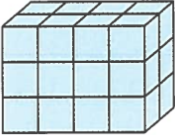
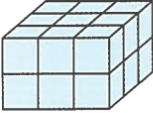

Unit (11) Assessment

[1] Choose the correct answer:

- a. Which of the following has the same number of vertices as the sphere ?
 A. Cube B. Cone C. Pyramid D. Cylinder
- b. Number of edges of cube + number of edges of cone = _____
 A. 12 B. 13 C. 24 D. 14
- c. Number of horizontal layers of  is _____
 A. 4 B. 2 C. 3 D. 24
- d. Cuboid of length 5 m, width 2 m and height 3 m, then its volume = _____
 A. 30 cm^3 B. 10 cm^3 C. 12 cm^3 D. 30 m^3
- e. Length of the missing dimension in the opposite figure its volume 48 cm^3 is _____ cm.
 A. 2 B. 3 C. 4 D. 5
- f. Capacity of water can be poured in a cuboid vessel of inner dimensions 30 cm, 20 cm and 10 cm equals _____ cm^3
 A. 60 B. 6,000 C. 5,000 D. 4,000
- g. Volume of  equals _____ 
 A. $[3 + 3] \times 2$ B. $[3 + 2] \times 3$ C. $3 \times 2 \times 3$ D. $3 + 2 + 3$



[2] Complete:

- a. Volume of the opposite compound shape is _____

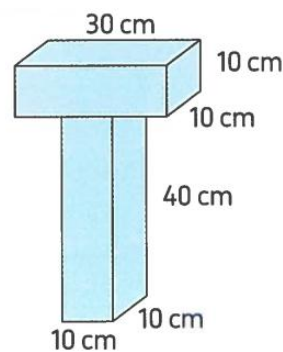

- b. Number of cube units of  is _____



- c. The 3 dimensions shape of one vertex is _____



- d. Rectangular prism has 2 horizontal layer and each layer has 6 cube units, then its volume = _____ cube units.
- e. Cuboid of base area 16 cm^2 and height 3 cm, then its volume = _____ cm^3
- f. Volume of cuboid is 40 cm^3 , its length 5 cm and width 4 cm, then its height = _____ cm
- g. Cylinder has _____ edges.
- h. Volume of cuboid = _____ \times height

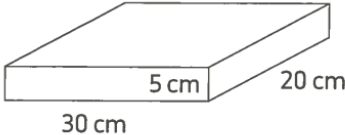

[3] Choose the correct answer:

- a. The volume of  is _____ cm^3
- A. 3,000 B. 300 C. 30 D. 30,000
- b. The cone has _____ vertex.
- A. 0 B. 3 C. 2 D. 1
- c. The _____ has no vertices, no edges and no faces.
- A. cylinder B. sphere C. cube D. cuboid
- d. The missing dimension of  is _____
- A. 5 cm B. 5 cm^3 C. 2 cm^3 D. 8 cm
- e. Number of horizontal layers in  is _____ layers.
- A. 4 B. 3 C. 2 D. 1
- f. If number of horizontal layers in a cuboid is 4 layers and each layer has 10 cube units, then its volume = _____ cube units.
- A. $10 + 4$ B. $10 - 4$ C. $10 \div 4$ D. 10×4
- g. Number of faces of cube Number of faces of cuboid.
- A. $>$ B. $<$ C. $=$





[4] Answer the following:

- a. Which is greater in volume? A cuboid of length 50 cm, width 40 cm and height 30 cm or a rectangular prism whose base area $3,000 \text{ cm}^2$ and height 15 cm.

- b. Ramy used 15 cubes to build a 3 dimensions shape if volume of each cube is 27 cm^3 , then find the volume of compound shape.

- c. Find the volume of obtained solid by folding the opposite shape.

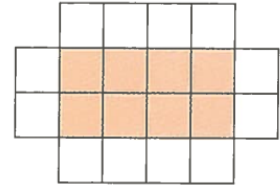

- d. Find the volume of the opposite figure.

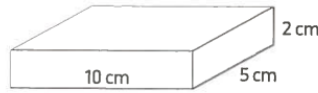





UNIT

12

Theme 4 | Applications of Geometry
and Measurement

Unit 12 Pie Charts and Applying Mathematical Learning

Photo Credit: Prachaya Roedseehaweecho / Shutterstock.com





Concept (12-1)

Lesson (1) Exploring Pie Charts

You have studied before how to represent data by line plot, bar graph, line graph or double bar graph.

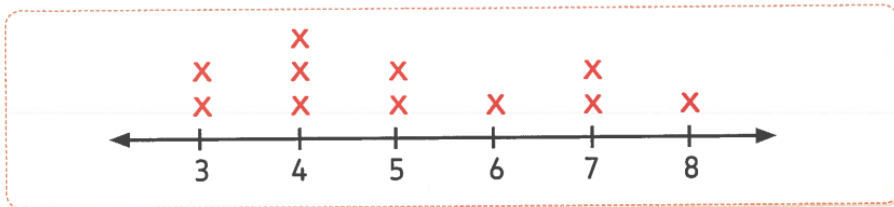

Line plot

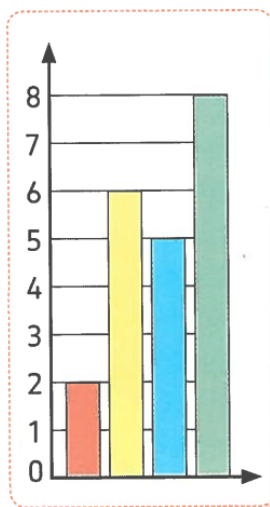

Bar graph

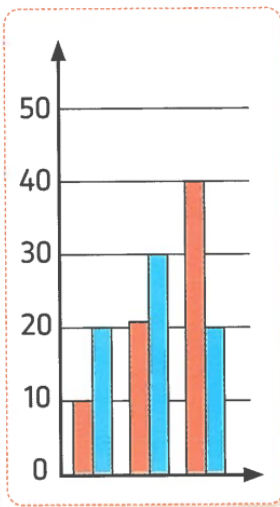

Double bar graph

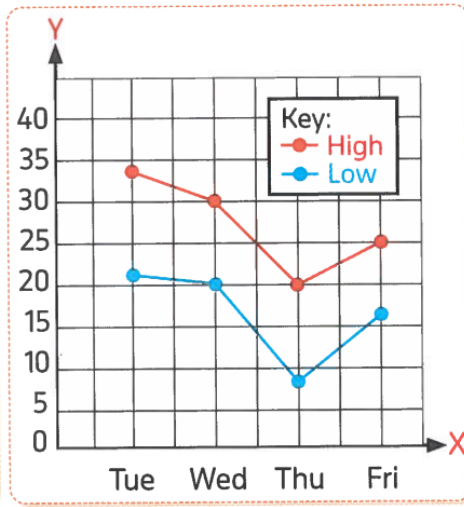

Line graph



What Sport Do Primary 5 Students Most Prefer?

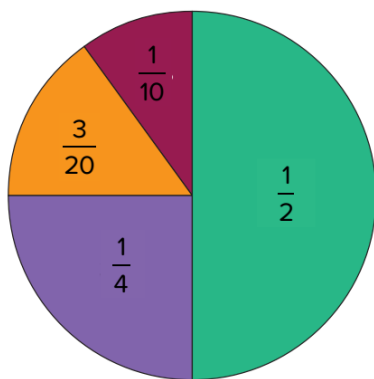

- Football
- Gymnastics
- Basketball
- Swimming





1. Shade $\frac{1}{2}$ of the circle red. Shade $\frac{1}{4}$ of the circle blue. Shade $\frac{1}{12}$ yellow.
Shade $\frac{1}{6}$ green.

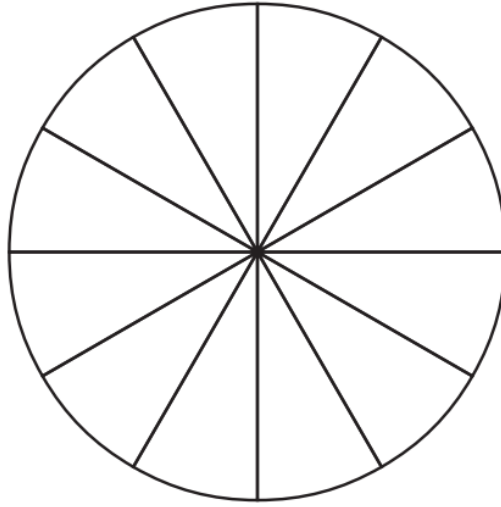

2. If this pie chart represents 24 students surveyed, how many students does the red section represent?
3. If this pie chart represents 24 students surveyed, how many students does the blue section represent?
4. What decimal of the group is blue?



For each task, select the circular degrees that match the fraction of the circle that is shaded. A circle has 360 degrees.

1.



- A. 180° C. 60°
B. 45° D. 90°

2.

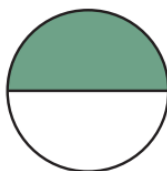

- A. 180° C. 120°
B. 90° D. 45°

3.



- A. 50° C. 60°
B. 120° D. 30°





4.

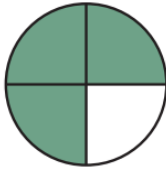

- A. 60° C. 150°
 B. 270° D. 120°

5.



- A. 45° C. 30°
 B. 60° D. 90°



The opposite figure shows the decimals of sales of different types of books. Complete :

- The sales decimal of French books is _____
- The sales decimal of Science books is _____
- The least sales decimal is in _____
- The ascending order of books types according to the decimals of sales is : _____ , _____ , _____ and _____

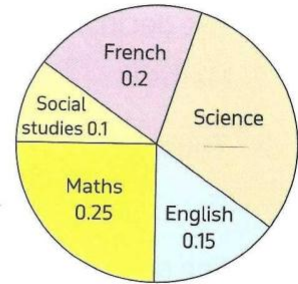

Lesson (2)

Interpreting Data in a Pie Chart

This is a pie chart without a title or a key. What could the pie chart represent?
Using the colors as a guide, what information can you gather about this pie chart?

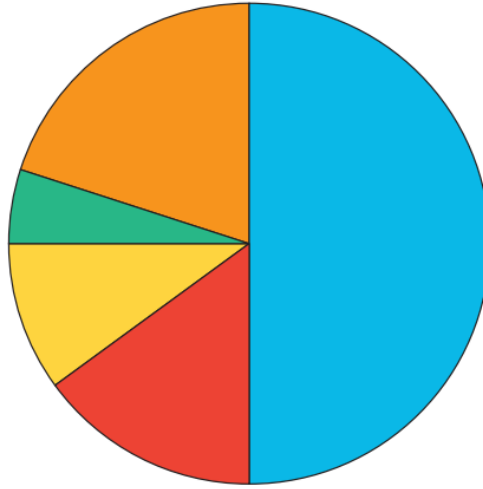

Now, give the pie chart a title and label the key based on the clues listed.

- 100 students were surveyed.
- 50 students selected chocolate ice cream.
- The smallest number of students selected mint ice cream.
- Twice the number of students who selected mint selected pistachio.
- 10 students selected pistachio ice cream.
- The same number of students selected vanilla ice cream as pistachio and mint combined.
- 20 students selected mango ice cream.

1. Title: _____

2. Key:

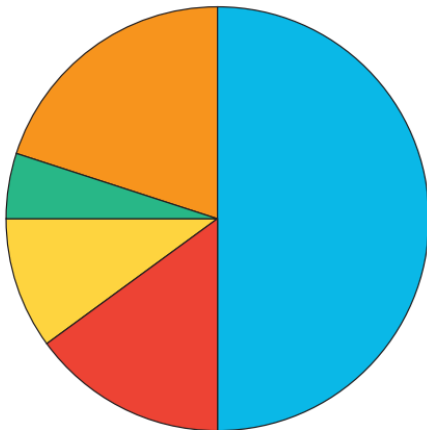

Color	Flavor	Number of Students
Blue	_____	_____
Orange	_____	_____
Green	_____	_____
Yellow	_____	_____
Red	_____	_____





Lesson (3)

Making Pie Chart

Shading Part of a Pie This frequency table shows the favorite ice cream flavors of a group of 50 children.

- Fill in the fractions in the simplest form for each flavor.

Flavor	Mango	Vanilla	Mastic	Chocolate	Hazelnut
Frequency	5	25	6	12	2
fractions	A. _____	B. _____	C. _____	D. _____	E. _____

- Work with your teacher and classmates to shade and label the pie chart using the data from the table. Include a title and a key.
- What is one question that could be answered by this pie chart?

Title: _____

Key:

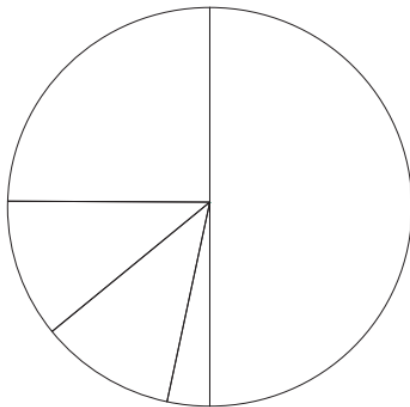

Flavor	Frequency	fractions
Mango	5	A. _____
Vanilla	25	B. _____
Mastic	6	C. _____
Chocolate	12	D. _____
Hazelnut	2	E. _____

Homework

- Shade in $\frac{3}{4}$ of the circle green, $\frac{1}{8}$ of the circle blue, and $\frac{1}{8}$ of the circle red.
- If this pie chart represents 40 students surveyed, how many students do the red and blue sections represent?
- What decimal of the group is green?

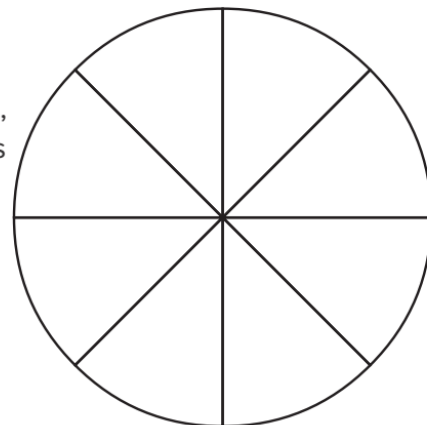

The opposite figure shows the favorite hobbies for 100 pupils in the fifth primary, study the figure, then answer.

- What is the fraction of the theatre with respect to all hobbies ?
- What is the fraction of the broadcast with respect to all hobbies ?
- What is the measure of the central angle of the sector of the music ?
- What is the hobby that the least pupils prefer ?
- What is the hobby that the most pupils prefer ?

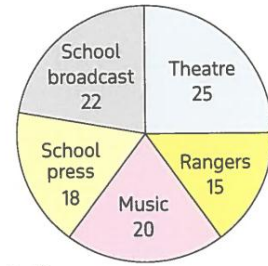

The following table shows the number of students who practice sports. Represent these data using the pie chart on the opposite figure.

Sport	Football	Basketball	Volleyball
Number of students	20	10	10

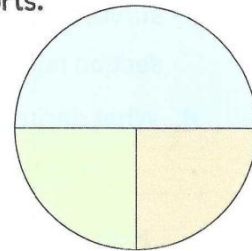

An employee spends his salary as follows.

- L.E. 200 for clothes.
- L.E. 800 for food.
- L.E. 400 for transportation and medicine.
- L.E. 200 for renting an apartment.

Graph that data on the opposite pie chart.

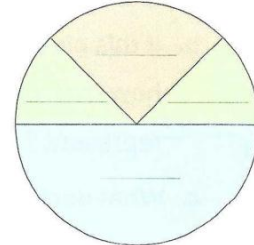

When some students were asked about the most popular TV programs, the following data were extracted.

- $\frac{1}{2}$ of the students like to watch sports programs.
- $\frac{1}{4}$ of the students like to watch cultural programs.
- $\frac{1}{8}$ of the students like to watch Arabic and foreign movies.
- $\frac{1}{8}$ of the students like to watch news.

- Represent that given data using the opposite pie chart.
- If the number of all students was 48 students, what is the number of students who prefer watching each type of programs ?

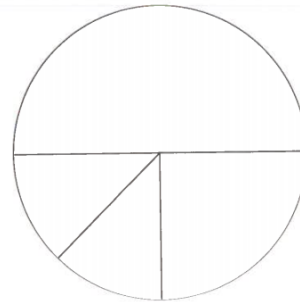



Choose the Correct answer:

1. The measure of the central angle that represents the opposite colored sector is _____

A. 36° B. 72°
C. 108° D. 120°

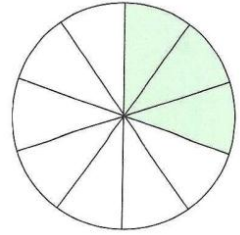

2. The following table shows the fractions of favorite colors of some children.

Color	Red	Blue	Green
Fractions	$\frac{1}{2}$	_____	$\frac{3}{10}$

What is the fraction that represents the red and blue colors together?

A. $\frac{1}{5}$ B. $\frac{1}{2}$ C. $\frac{3}{10}$ D. $\frac{7}{10}$

3. The opposite figure represents the fractions of the sports activities for the pupils of a school, their number is 960 pupils.

First : The fraction of the pupils participated in handball = _____

A. $\frac{1}{10}$ B. $\frac{1}{5}$
C. $\frac{3}{10}$ D. $\frac{2}{5}$

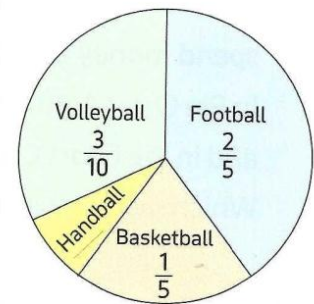

Second : The number of pupils who participated in football activity = _____ pupils.

A. 96 B. 384 C. 480 D. 672

4. The following table shows the number of studying hours that Tamer did in a week :

Subject	Arabic	Maths	Science	English	Social studies	Total
Number of hours	6	10	7	9	4	36

, then the decimal of English = _____

A. 0.2 B. 0.25 C. 0.3 D. 0.35

5. The measure of the central angle of the circular sector that represents $\frac{1}{8}$ the circle is _____ $^\circ$

A. 30 B. 45 C. 60 D. 90



تطبيق



مذكرات جاهزة للطباعة

لتحميل الملفات التعليمية مجاناً للمعلم والطالب

مذكرات وملازم / مراجعات وملخصات / امتحانات / كتب الوزارة /
أدلة المعلم / دفاتر التحضير / سجلات مدرسية / أوراق تأسيس

امسح الكود بموبايلك علشان تقدر تثبت التطبيق

وتقدر ف أي وقت تحمّل ال نفسك فيه ببلاش

هيغنيك عن البحث والجروبات والقنوات الكتيرة



تطبيق الموبايل لتحميل الملفات