

# PRIMARY 1 DISCOVER



2025-2026



## FOREWORD

**T**he MOETE launched Egypt's reform vision for the development of education, and the process of developing curricula comes at the heart of this vision. The implementation of this vision was heralded in 2018, starting with the kindergarten stage in its first and second grades, with the aim of continuing until the end of the secondary stage.

**T**his vision endeavored to make major transformations in the teaching and learning processes, where there is a transition from acquiring knowledge to producing it, and from learning skills to employing them both in specific learning situations and in the general life of the learner outside the classroom. Our curricula also integrate values that contribute to the establishment of our society—values which pose as a protective fort for our homeland. Egypt's reform vision for curriculum development also aims to take into account the specifications of pre-university education graduates, as well as the challenges Egypt faces locally, regionally, and globally. The developed curricula are intended to foster a citizen who is capable of engaging in civilized conversations and positive dialogues with the other, in addition to acquiring digital citizenship skills.

**I**n this regard, the MOETE extends its gratitude and appreciation to the Central Administration for Curriculum Development. It also extends its thanks and gratitude to Discovery Education for their active participation in the preparation of this book. Gratefulness also goes to all the Ministry's experts who contributed to the enrichment of this work.

**T**his transformation of Egypt's education system would not have been possible without the significant support of Egypt's current president, **His Excellency President Abdel Fattah el-Sisi**. Overhauling the education system is part of the President's vision of "rebuilding the Egyptian citizen" and it is closely coordinated with the Ministries of Higher Education and Scientific Research, Culture, and Youth and Sports. The new education system is only a part in a bigger national effort to propel Egypt to the ranks of developed countries, and to ensure a great future for all of its citizens.

**Reviewed by**

**The Central Administration for Curriculum Development**

**Supervised by**

**Dr Akram Hassan**

**Head of the Central Administration for Curriculum Development**

NAME: \_\_\_\_\_

## CONTENTS

### First term

#### Term 1

##### Theme 1: Who Am I?

Chapter 1 : All About Me	1
Chapter 2 : Family Tree	13
Chapter 3 : Our Community	17

##### Theme 2: The World Around Me

Chapter 1 : Our Environment	21
Chapter 2 : Moving Around Our Environment	25
Chapter 3 : Growing Food In The World Around Us	31
Chapter 4 : Celebrating The World Around Us	35

### Second term

#### Term 2

##### Theme 3 : How The World Works?

Chapter 1: How Goods are Made Around the World	41
Chapter 2: How Business Works	49
Chapter 3: Buying, Selling, and Saving	55

##### Theme 4: Communication

Chapter 1: Communicating with Numbers	59
Chapter 2: Communicating with Art	63

# WHO AM I?

## CHAPTER 1: ALL ABOUT ME



# I AM AN EGYPTIAN

**My features come from the features of my ancestors, the Ancient Egyptians .**

**I have pride in their writing, which remains until today and talks about their achievements and the antiquity of the Ancient Egyptian civilization that was introduced to humanity.**

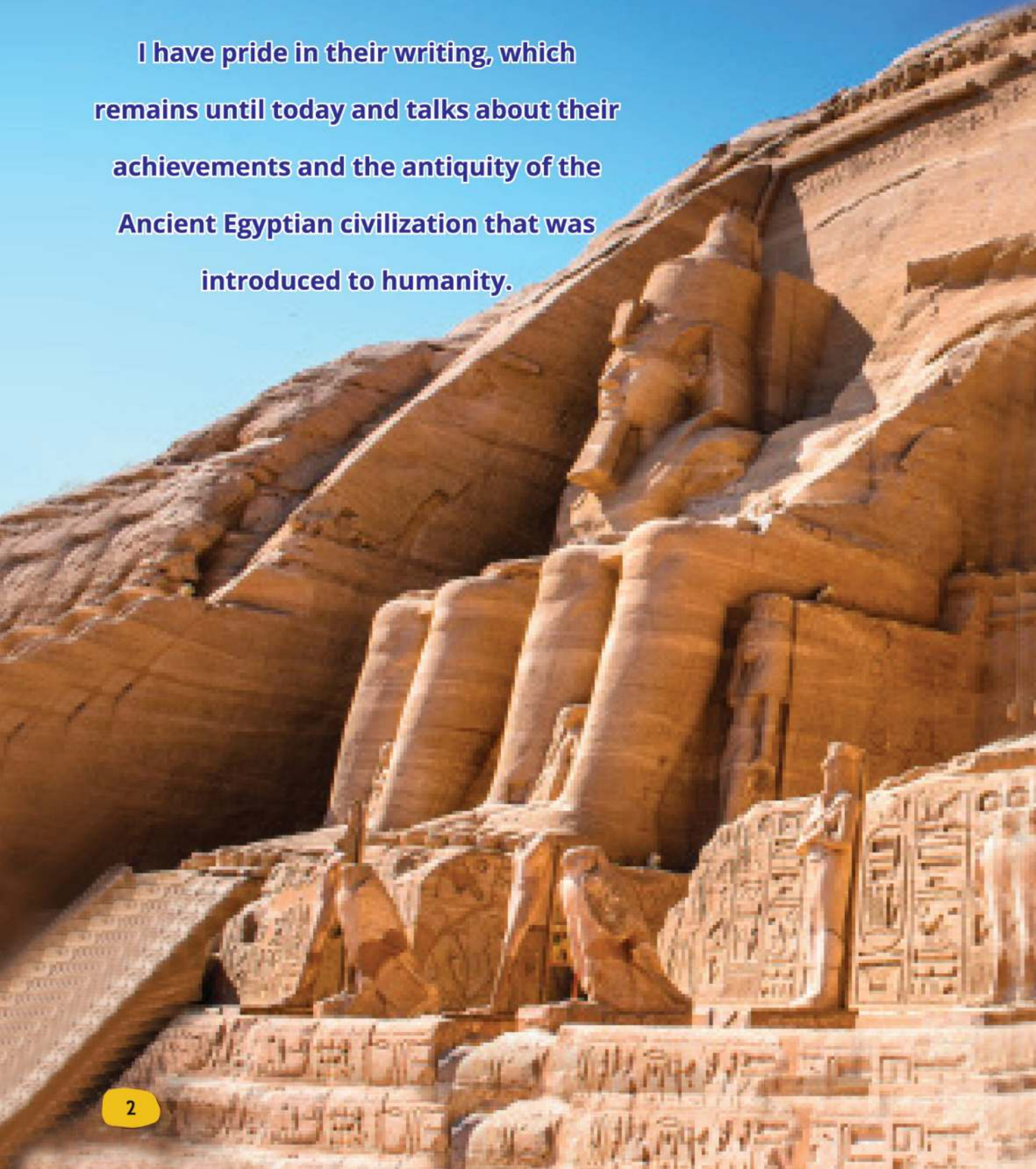













## Hieroglyphic Writing

The Ancient Egyptians used the hieroglyphic writing to record the important events in their life, and this writing appeared on many monuments such as temples, tombs, pyramids, and statues.

➔ Some hieroglyphic signs:

Hieroglyphic signs	Pronunciation	Hieroglyphic signs	Pronunciation
 Eagle	a	 Foot	b
 Leaf	i	 Viper	f
 Forearm	a	 Owl	m
 Quail	w	 Water	n

Hieroglyphic signs	Pronunciation
 mouth	r

 Bolt	s
---	---

 Hill	q
--	---

 Basket	k
---	---

 Loaf	t
---	---

 Hand	d
---	---

Hieroglyphic signs	Pronunciation
 Snake	j

 Vulture	mwt
--	-----

 Arrow	sn
---	----



 Duck	sa
---	----





 Face	hr
---	----

 Lake	sh
---	----



## Hieroglyphic Writing

The hieroglyphic signs	Pronunciation	The meaning
	it	father
	mwt	mother
	sn	brother
	snt	sister
	sa	son
	sat	daughter
	st	woman
	jd	say

The hieroglyphic signs	Pronunciation	The meaning
	rm	fish
	hr	face
	ra	sun
	iah	moon

➔ **Determinative:**

The Ancient Egyptian used the Determinative, which is a hieroglyphic sign that comes at the end of the word to clarify its meaning, and it does not represent a phonetic value (that is, it is not pronounced), and it was illustrated in red in some words:



Seated man, sometimes used as A determinative, to indicate that the word is masculine.



Seated woman, sometimes used as A determinative, to indicate that the word is feminine.



## PICTURE OF ME AND MY SENSES

DIRECTIONS: Draw a picture of yourself.

My name: \_\_\_\_\_



## A FAMILY AT THE PARK

DIRECTIONS: Circle the brother and sister.  
Then finish coloring the picture.





## EXTENDED FAMILY

**DIRECTIONS:** Grandmother reads a book. Circle this.  
Aunt Sara talks to mom. Circle this in a different color.  
Nabil shows his cousin a new toy. Draw a box around this.





## OUR FIVE SENSES

DIRECTIONS: Draw lines to match each sense with its helping body part.

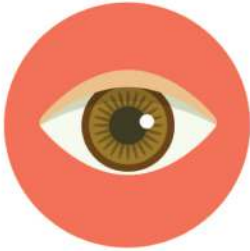

Sight



Hearing



Smell



Touch



Taste



## SIMILARITIES AND DIFFERENCES

Directions: Answer these questions by yourself or with a partner.

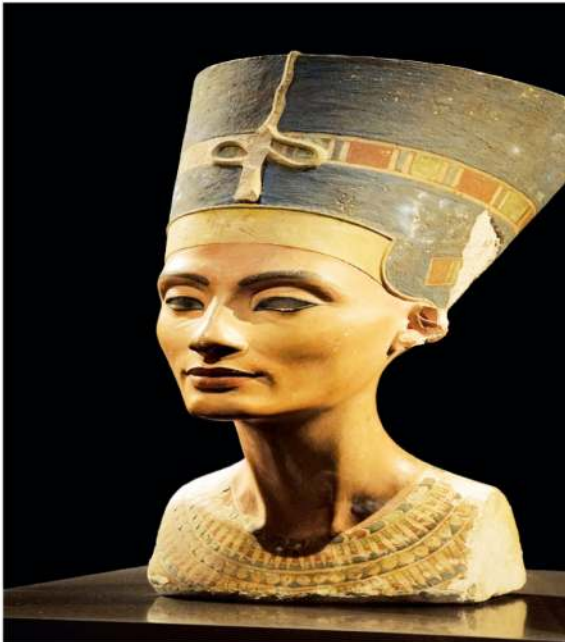

### BUST OF NEFERTITI (1370-1330 BC)

How are you the same as  
Nefertiti?

How are you different?



### DR. MAGDI YACOUB

What do you see in this portrait?

What colors do you see?

What parts of the face can you  
name?



## MY PICTURE

**DIRECTIONS:** Meet some new friends. How are they like you?  
How are they different?



Hi, my name is Karim.  
I have short hair.  
I wear glasses.  
I live in Egypt.  
My family is from Aswan.  
I love playing football.

Hi, my name is Mona.  
I am seven years old.  
I like to wear braids.  
I love reading.  
I love riding bikes.



# WHO AM I?

## CHAPTER 2 : FAMILY TREE





## MIXED-UP ROUTINE

**DIRECTIONS:** These routines are not in the right order.  
Number the steps 1, 2, 3, 4 to show the correct order.





## ADULTS AND BABIES

DIRECTIONS: Match the adults to the babies.





## LIFE STAGES OF A HUMAN

DIRECTIONS: Study the life stages of humans.

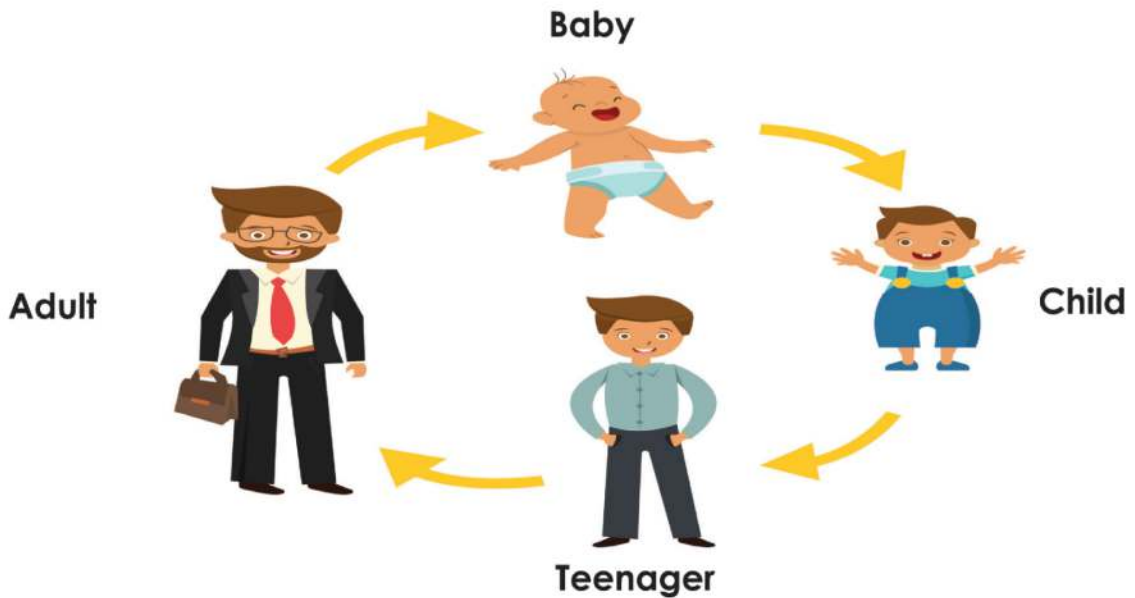

## LIFE CYCLE OF A PLANT

DIRECTIONS: Study the life cycle of a plant.

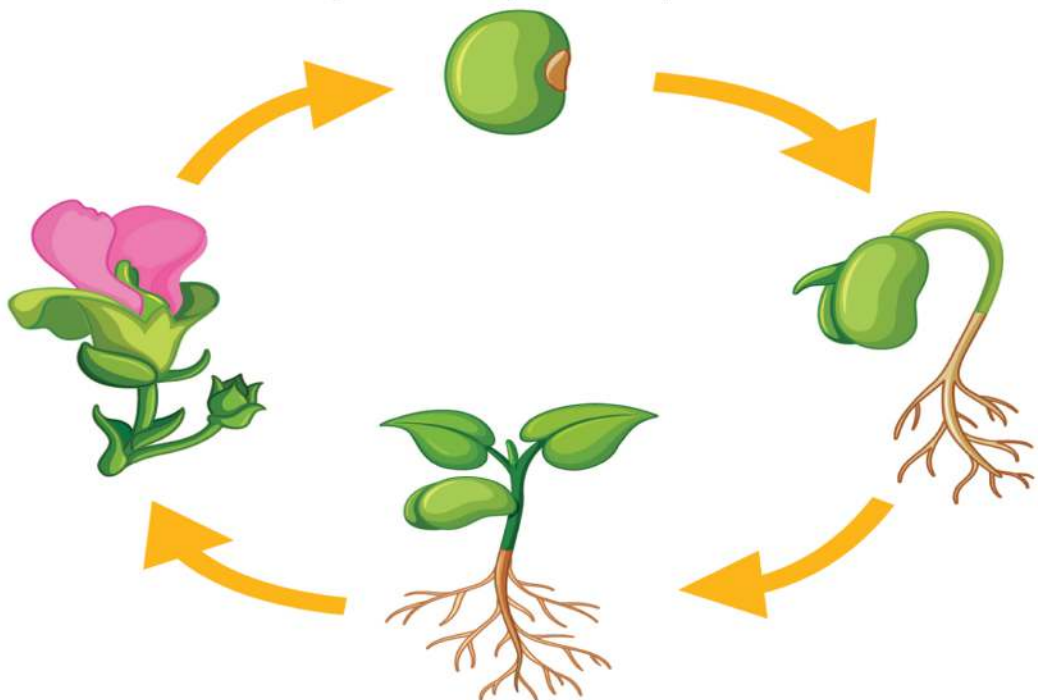

# WHO AM I?

## CHAPTER 3 : OUR COMMUNITY



 **OUR RIGHTS**

**DIRECTIONS:** Trace the words below. Write the first letter of your name in each box. This shows you agree with the right.

**WE HAVE THE RIGHT TO:**



BE SAFE







LEARN





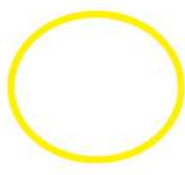

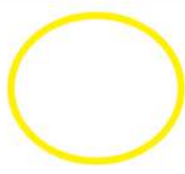
SHARE IDEAS

 **RULES**

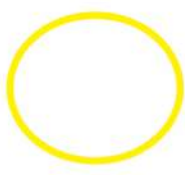
**DIRECTIONS:** Draw a smiley face in the circle if the student is following the rules. Draw a frowning face in the circle if the student is not following the rules.

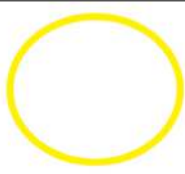

# COMMUNITY HELPERS

**DIRECTIONS:** Match the community helper with the place where he or she would work.





## WORKERS TOOLS

**DIRECTIONS:** Match the workers with the tool used to do the job.



**DIRECTIONS:** In the box next to the doctor, draw an important tool that he or she uses every day.

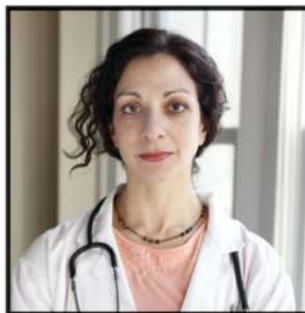

# THE WORLD AROUND ME



## CHAPTER 1: OUR ENVIRONMENT



# IS IT LIVING?

**DIRECTIONS:** Write yes or no in each box.

Is it living?				
Does it move by itself?				
Does it need air?				
Does it need food and water?				
Does it grow and change?				
Object	 Bird	 Rock	 Tree	 Slide



## DESERT AND DELTA

**DIRECTIONS:** Write an important detail about the desert and Delta.

Draw a picture of the desert and Delta.

Circle the animals you think live in the desert.

Draw a square on the animals you think live in Delta.

Four sets of handwriting lines, each consisting of a solid top blue line, a dashed middle pink line, and a solid bottom blue line.

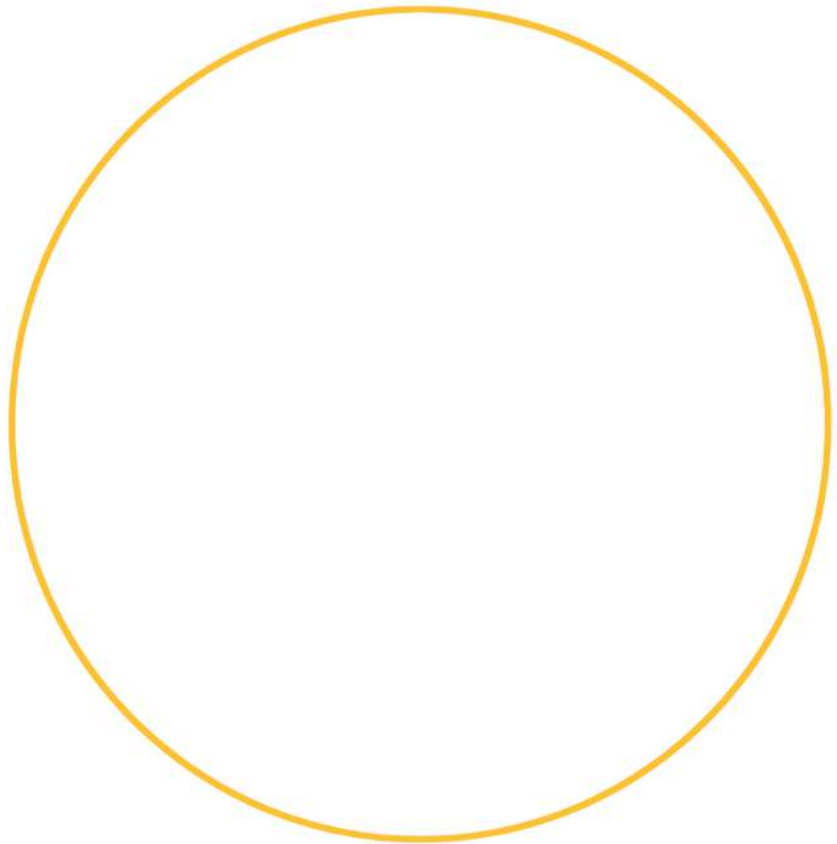



## TAKE CARE OF THE ENVIRONMENT

**DIRECTIONS:** Put a red X through the actions that will hurt the environment. Put a green circle around the actions that will help take care of your surroundings. Color the pictures.

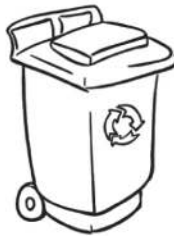

# THE WORLD AROUND ME

A colorful illustration of two children standing in a green field under a blue sky with white clouds. On the left is a girl with short black hair, wearing a pink and white striped shirt and a pink skirt, with her right hand near her chin. On the right is a boy with curly brown hair, wearing an orange t-shirt and tan pants, with his left hand on his head. The background features stylized green bushes and a bright blue sky with several white clouds of various shapes.

## CHAPTER 2 : MOVING AROUND OUR ENVIRONMENT



# PLANT DIAGRAM

**DIRECTIONS:** Use the word bank to label the parts of the plant.  
Draw a line from the plant part to its function.

Leaves

flower

roots

stem

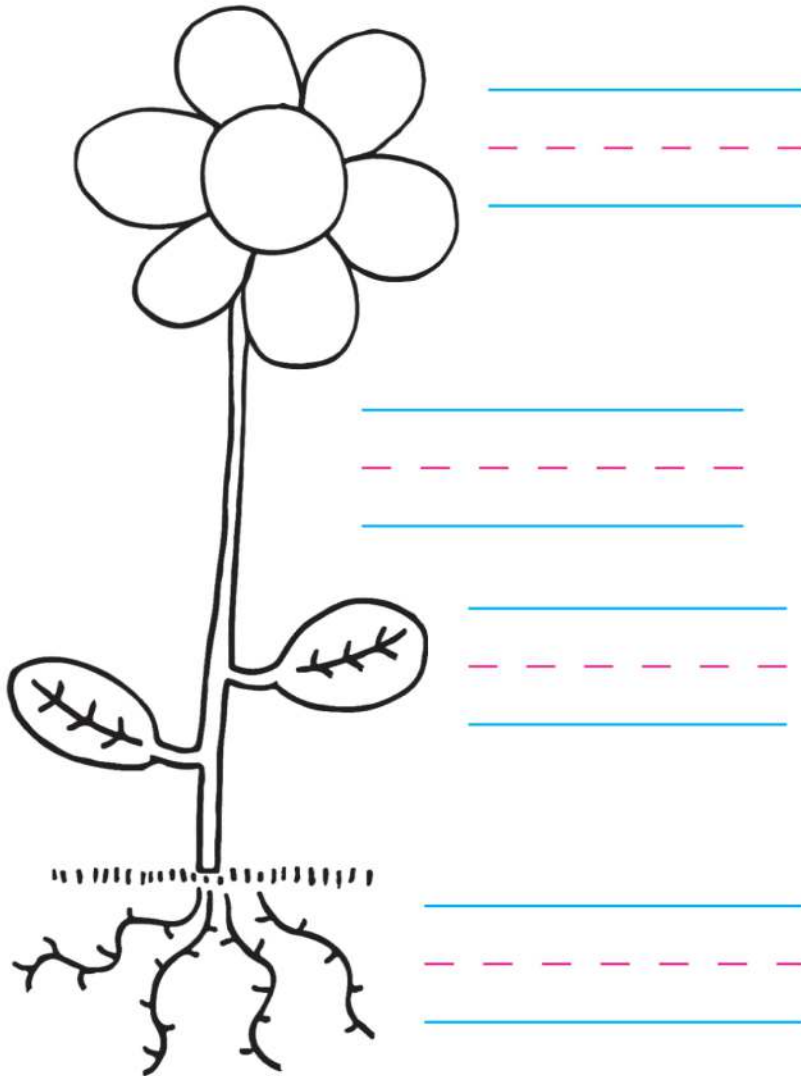

Holds the plant in the ground. Soaks water from the soil.

Holds the plant up. Carries water from the roots to the different parts of the plant.

Lets in air. Uses sunlight to make food.

Makes seeds.



# ANIMAL DIAGRAMS

DIRECTIONS: Use the word bank to label the parts of the animals.

shell

wing

fin

claws

teeth

tail

beak

feathers

scales

\_\_\_\_\_

-----

\_\_\_\_\_



\_\_\_\_\_

-----

\_\_\_\_\_

\_\_\_\_\_

-----

\_\_\_\_\_



\_\_\_\_\_

-----

\_\_\_\_\_

\_\_\_\_\_

-----

\_\_\_\_\_



\_\_\_\_\_

-----

\_\_\_\_\_

\_\_\_\_\_

-----

\_\_\_\_\_



\_\_\_\_\_

-----







\_\_\_\_\_



## HOW ANIMALS MOVE?

**DIRECTIONS:** Sort the animals by how they move.

Write the name of your favorite animal in each group.

ANIMAL	WALK, RUN, HOP	SWIM	FLY
 rabbit			
 elephant			
 butterfly			
 owl			
 penguin			
 dolphin			
 cricket			
My favorite animal			



## HOW OBJECTS MOVE INVESTIGATION?

**DIRECTIONS:** Test each object to see how it can move.

Write yes or no in each box.



Object	Bounce	Roll	Spin	Slide
Ball				
Block				
Pencil				





## TRANSPORTATION IN EGYPT

**DIRECTIONS:** Look at the pictures below. Write the name of each type of transportation. Mention its type (Land - Air - Sea) then put (✓) in front of the one that pollutes the environment.

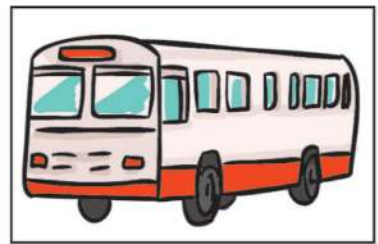
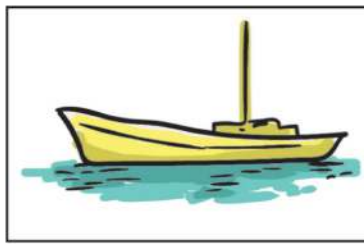
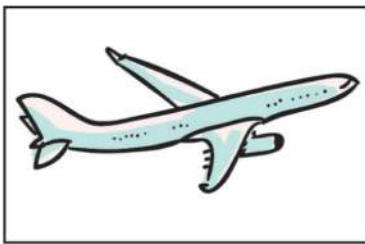
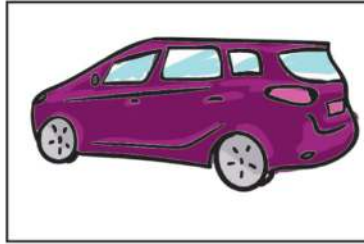
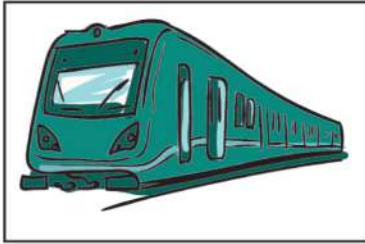

## DOES IT CAUSE POLLUTION?

**DIRECTIONS:** Use the previous pictures, then complete the table.

Pollution 	No Pollution 

The background features a bright blue sky with several white, fluffy clouds of various sizes. Below the sky is a green field with rolling hills. In the foreground, two children are standing. On the left is a girl with short black hair, wearing a pink and white striped short-sleeved shirt and a pink dress. She has her right hand raised to her chin in a thoughtful pose. On the right is a boy with curly brown hair, wearing an orange short-sleeved shirt and light-colored pants. He has his left hand on his head and a slight smile. The overall style is simple and colorful, typical of children's educational materials.

# THE WORLD AROUND ME

## **CHAPTER 3 : GROWING FOOD IN THE WORLD AROUND US**



## THE SUN IN THE SKY

DIRECTIONS: Read the story. Use a yellow crayon to color the sun.

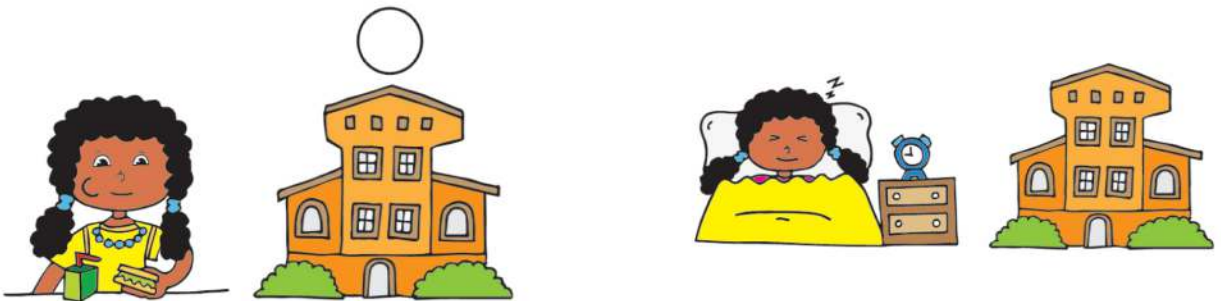
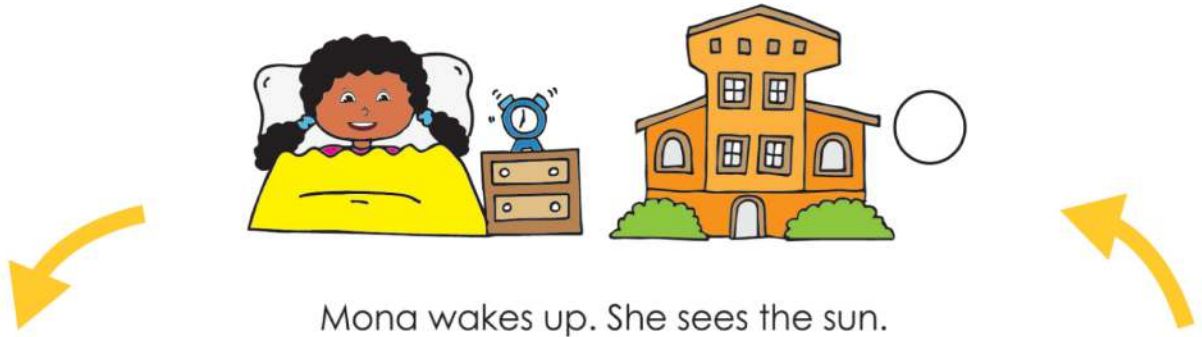



## SEASONS OF THE YEAR



**DIRECTIONS:** Listen to your teacher.

Then write the season name under each picture.

1. Each season of the year, weather changes,  
Weather changes, weather changes.  
Each season of the year, weather changes  
All year long.



2. The leaves on the tree fall to the ground.  
To the ground, to the ground.  
The leaves on the tree fall to the ground,  
All fall long.



3. The weather outside is cold and rainy  
Cold and rainy, cold and rainy.  
The weather outside is cold and rainy  
All winter long.



4. The flowers and leaves are starting to grow  
Starting to grow, starting to grow.  
The flowers and leaves are starting to grow,  
All spring long.



5. The weather outside is hot and sunny  
Hot and sunny, hot and sunny.  
The weather outside is hot and sunny  
All summer long.



## HEALTHY FOOD CHOICES

DIRECTIONS: Circle the healthy food choices.



The background features a bright blue sky with several white, stylized clouds of various sizes. Below the sky is a green field with rolling hills. In the foreground, two children are depicted. On the left is a girl with short black hair, wearing a pink and white striped short-sleeved shirt and a pink skirt. She has her right hand raised to her chin in a thoughtful or listening pose. On the right is a boy with curly brown hair, wearing an orange t-shirt and light-colored pants. He has his left hand on his hip and his right hand raised to his head, looking towards the girl.

# THE WORLD AROUND ME

## **CHAPTER 4 : CELEBRATING THE WORLD AROUND US**



## EGYPTIAN FEASTS

**DIRECTIONS:** Read the story to discover what happens during different feasts. Draw a picture to show what happens during each feast. Label the pictures.

**NEW YEAR'S EVE:** It is New Year's Eve. Families celebrate together. Fireworks go off in the sky. Children get new and colorful clothes. Girls and boys get sweets and toys.

**EID AL-FITR:** It is Eid al-Fitr. Families celebrate together and visit relatives. They pray together. They eat ka'ak. Children get new clothes. Children get Eid-ey-yah.

**EID AL-ADHA:** It is Eid al-Adha. Families celebrate together. They pray together and watch the sacrifice of the sheep. They eat Fattah and visit their families. Children get new clothes. Children get Eid-ey-yah.

**CHRISTMAS:** It is Christmas (Eid Almilad), which is celebrated on January 7. Families celebrate together. They eat lots of meat. Eid Milad Majid!



## EGYPTIAN TRADITIONS

**DIRECTIONS:** Read the information to discover some Egyptian traditions.

**SONGS:** One traditional song is about the life of Beni Helal. The singer plays the Rababa.

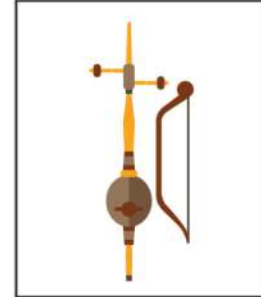

**FOOD:** Koshari is a traditional Egyptian dish. It is made with rice, lentils, and tomato sauce. Another traditional dish is Ful medames. It is made with soft beans.



**CLOTHING:** Traditional costumes depend on where people live. Many years ago, women in Alexandria and other regions used to wear melaya laf. Men used to wear galabiyas, trousers, and koftans.





## EGYPTIAN MONUMENTS

**DIRECTIONS:** Read about these Egyptian monuments.



The **Temple of Hatshepsut** is located on the west bank of the Nile River. The temple is built into a cliff. It was built to honor Queen Hatshepsut.



The **Luxor Temple** is located on the east bank of the Nile River. The temple was dedicated to bury three Egyptian kings.



The **Sphinx** is located in Giza on the west bank of the Nile River. It is the largest statue in the world. It has the head of a human and the body of a lion.



The **Pyramids of Giza** are located in Giza. They are the most famous Egyptian monument. There are three pyramids and Great Pyramid of Khafu is the largest and tallest pyramid in Egypt.



## TRAVELING TO EGYPTIAN MONUMENTS

**DIRECTIONS:** Look at the map below. Draw a large “✓” where you are located. Then identify the direction and type of transportation to visit one of the historical places on the map.

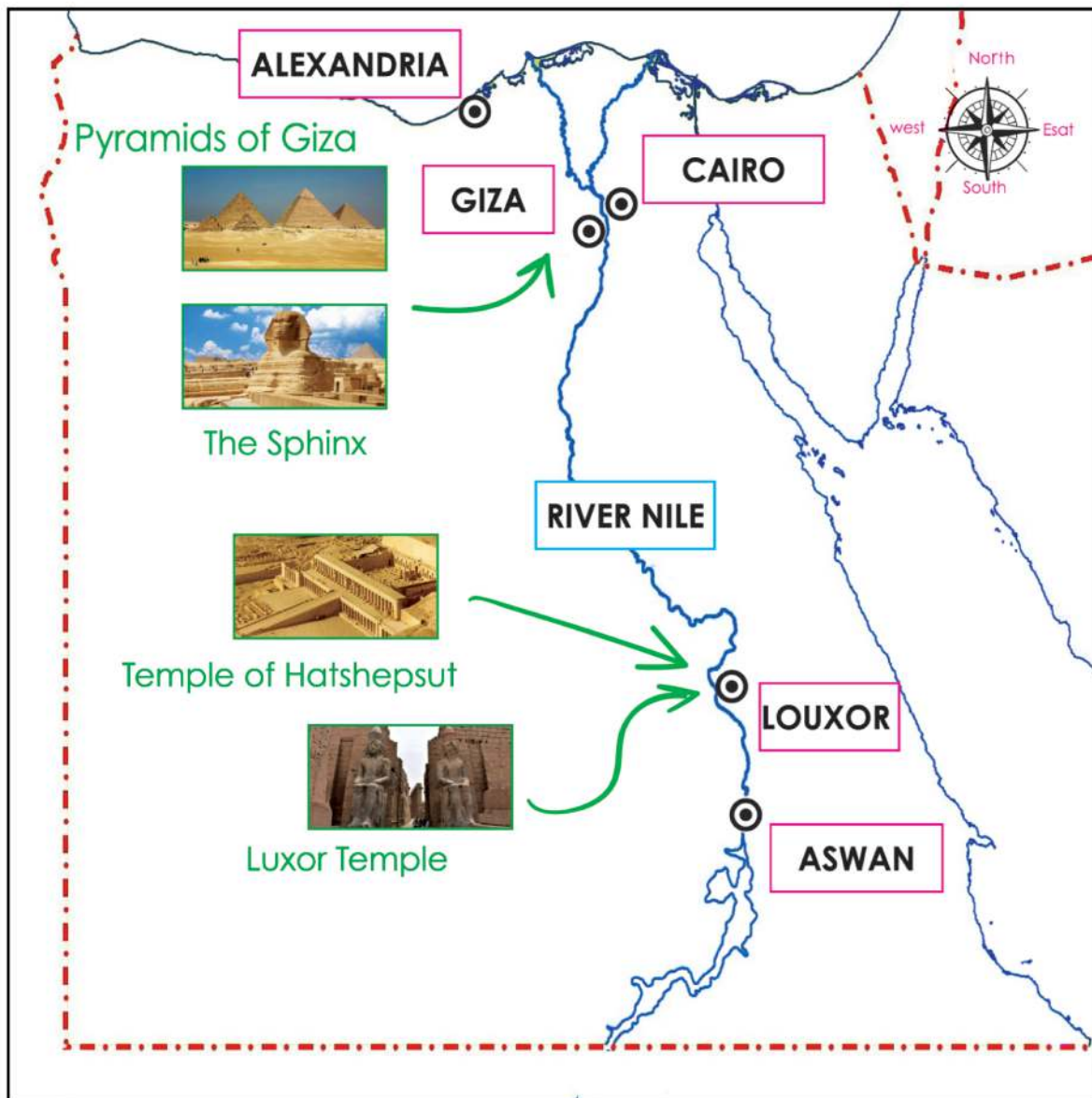



## RESPECTING EGYPTIAN MONUMENTS

**DIRECTIONS:** Read the list of appropriate behaviors for visiting monuments or historical sites.

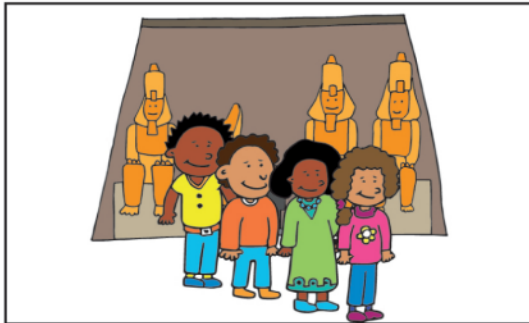

**STAND IN LINE TO  
WAIT YOUR TURN**

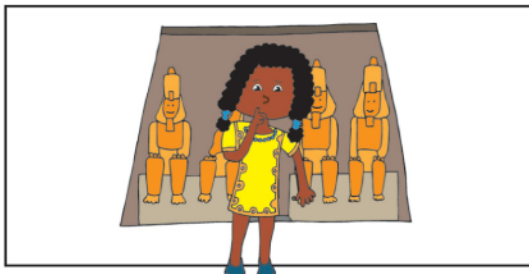

**BE SILENT OR SPEAK QUIETLY**

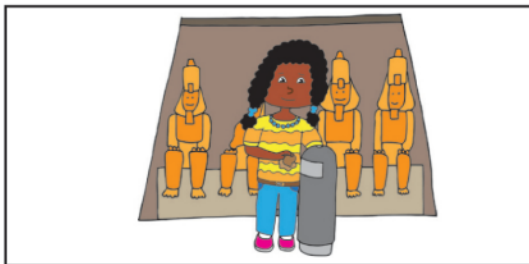

**KEEP CLEAN**

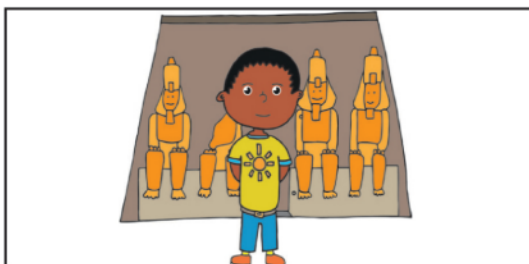

**DO NOT TOUCH ANYTHING  
UNLESS INVITED TO DO SO**

# TERM 2

HOW THE WORLD WORKS?

CHAPTER 1

## HOW GOODS ARE MADE

## AROUND THE WORLD





## NEEDS OR WANTS?

Trace each label on the chart below.

Sort the things that make you happy into the correct columns.





NEEDS	WANTS





## TYPES OF GOODS

Write each item from the list on the board under the correct type of good.

 CLOTHING	<hr/> <hr/> <hr/> <hr/>	 TOYS	<hr/> <hr/> <hr/> <hr/>
 FOOD	<hr/> <hr/> <hr/> <hr/>	 HYGIENE	<hr/> <hr/> <hr/> <hr/>



## STORES AND MARKETPLACES

Write each item from the list on the board under the place where you can buy it.

 GROCERY STORE	<hr/> <hr/> <hr/> <hr/>	 BOOK STORE	<hr/> <hr/> <hr/> <hr/>
 PHARMACY	<hr/> <hr/> <hr/> <hr/>	 MARKET	<hr/> <hr/> <hr/> <hr/>



## MATERIALS MAZE

Follow each maze from the good to the resource used to make it.

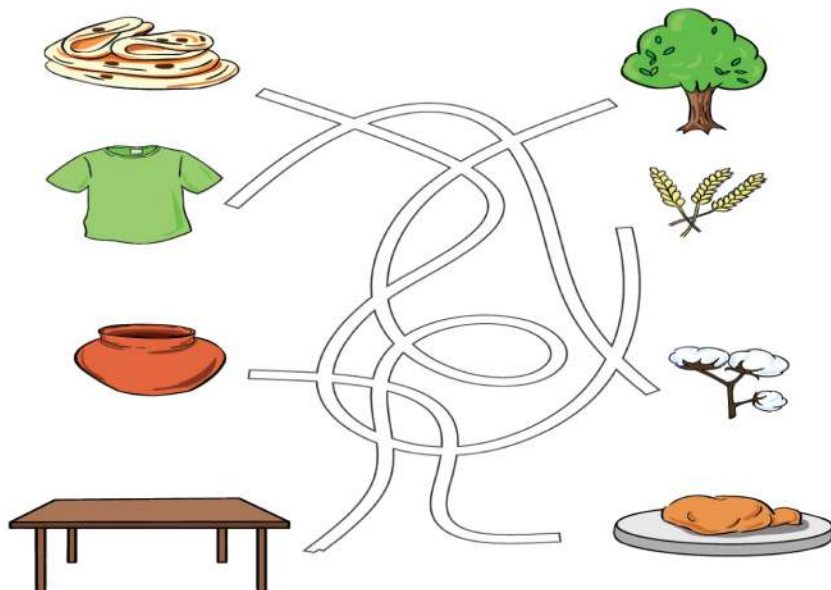

## STAGES OF MAKING A PRODUCT

Study the diagram below to learn the stages in creating clothing. Say each word out loud as you read it.





## THROW AWAY OR RECYCLE CLOTHING?

Draw and color a picture of what happens when you throw away and recycle clothing.

When I Throw Away Clothes:

When I Recycle Clothes:



Decide if it is better to throw away or recycle your old clothing, and write a sentence explaining why.

It is better to THROW AWAY / RECYCLE my old clothing because

Handwriting practice lines consisting of four sets of three horizontal lines: a solid blue top line, a dashed pink middle line, and a solid blue bottom line.



## TECHNOLOGY AND THE T-SHIRT

Read the text below to learn how technology helps people make clothing more easily.



Planting cotton in fields.



Collecting cotton using a cotton harvesting machine.



Separating seeds using a cotton gin machine.



Spinning and waving cotton, then turning it into yarn then cloth.



Making a T-shirt from fabric.



## APPLIANCES

In each box, complete the drawing of an appliance. Then, match each appliance with the correct action.

Cool the air

Heat up food

Clean clothes

Keep food cold

Find information

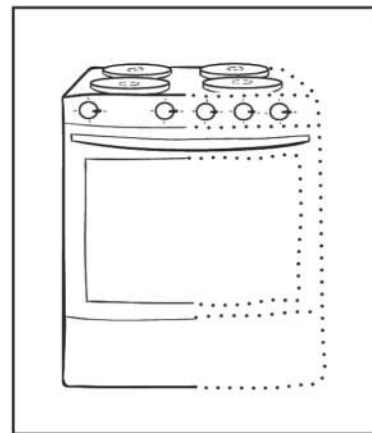
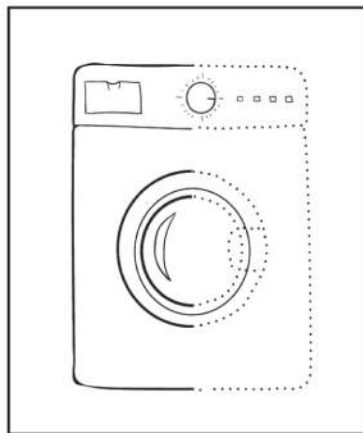
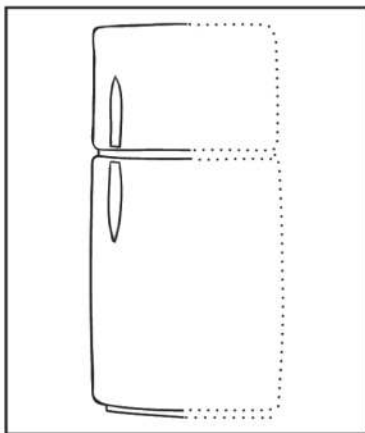
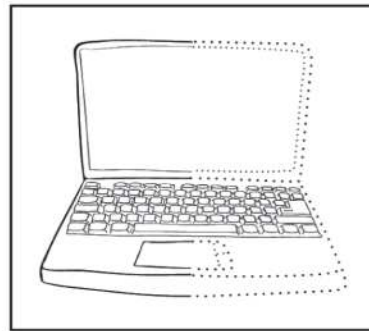
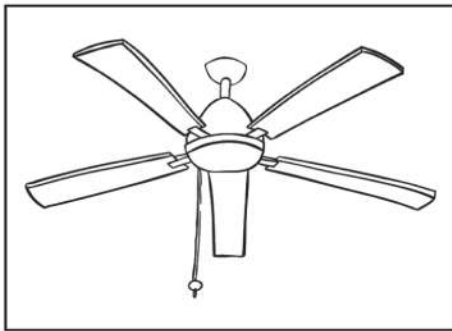



## CONSERVING WATER

Study the home below. Circle places where you could do something to help conserve water.

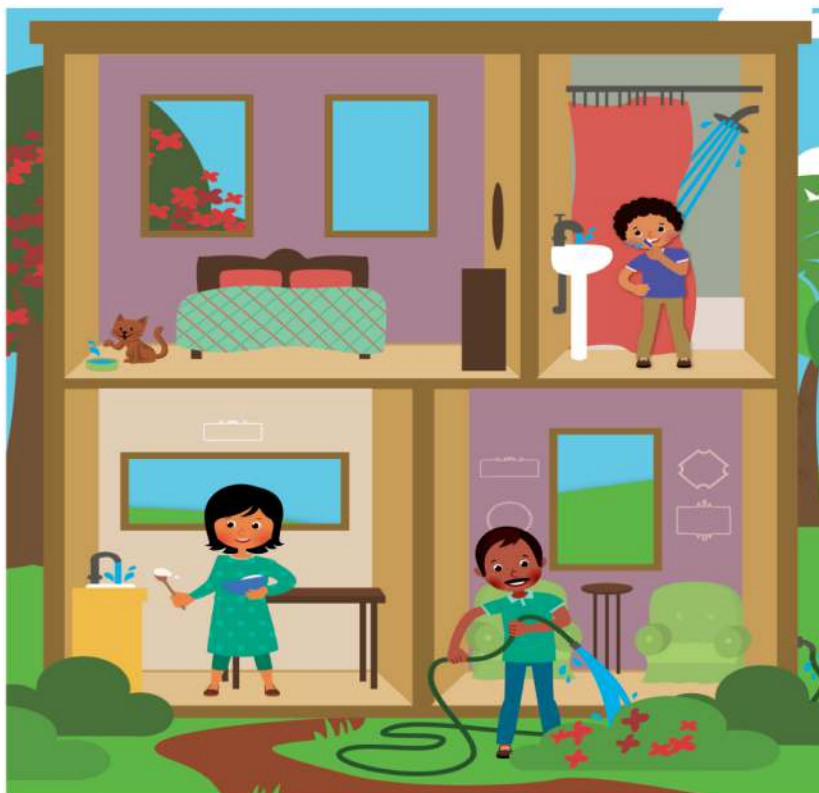

## WATER PLEDGE

Complete the pledge below. Draw a picture to show your promise.

**I PLEDGE TO CONSERVE WATER AT HOME. I WILL DO THIS BY:**

Blank writing area with three horizontal lines (top and bottom solid, middle dashed) for a pledge.

HOW THE WORLD WORKS?

CHAPTER 2

# HOW BUSINESS WORKS





## AT WORK

Read the text below. Underline the PLACE in blue. Underline the JOB in green. Underline the TOOLS in orange.

This is a meat market. A butcher works at the meat market. The butcher cuts the meat with a knife. The butcher uses a scale to weigh the meat.



This is a bank. A teller works at the bank. The teller adds up money with a calculator. The teller types amounts of money into the computer.

This is a bakery. A baker works at the bakery. The baker uses a mixer to mix the ingredients. The baker puts the bread in the oven to cook.



This is a garage. A mechanic works at the garage. The mechanic changes a tire with a wrench. The mechanic uses a funnel to change the oil.



# MIXED UP WORK

Match the job with the correct place and tools.

PLACE

JOB

TOOL





## TYPES OF TRANSPORTATION

Use your crayons to color the pictures of the types of transportation that would be used to move goods.

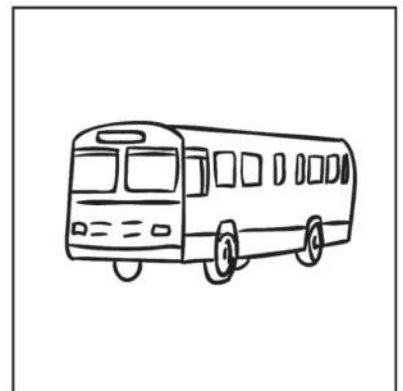
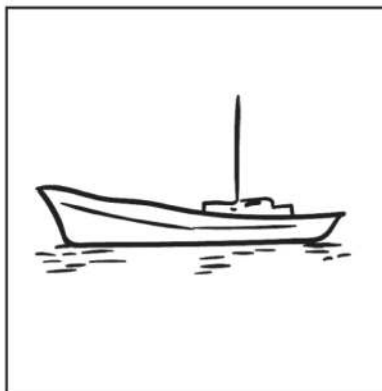
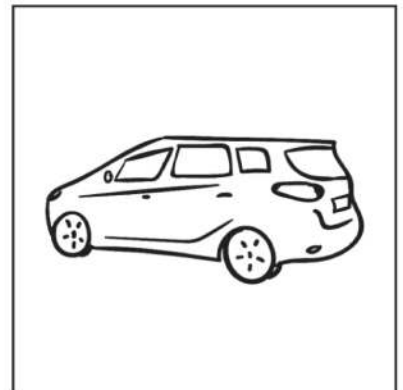
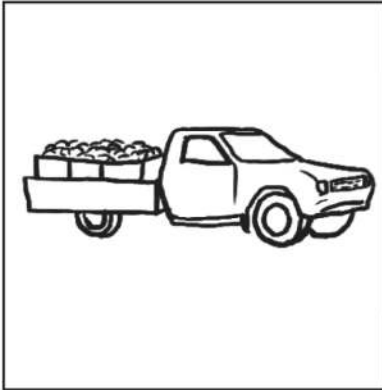

 **DOES IT ATTRACT?**

Test each item , bring (paper clips- pin - wooden clips - paper - plastic ball) using your magnet. If the item sticks to the magnet, write the name in the “YES” column. If the item does not stick to the magnet, write its name in the “NO” column.

YES	NO

 Complete the definition of “magnet.”  
 \_\_\_\_\_  
 \_\_\_\_\_

A magnet; \_\_\_\_\_

 **COMPASS** Compare the pictures.

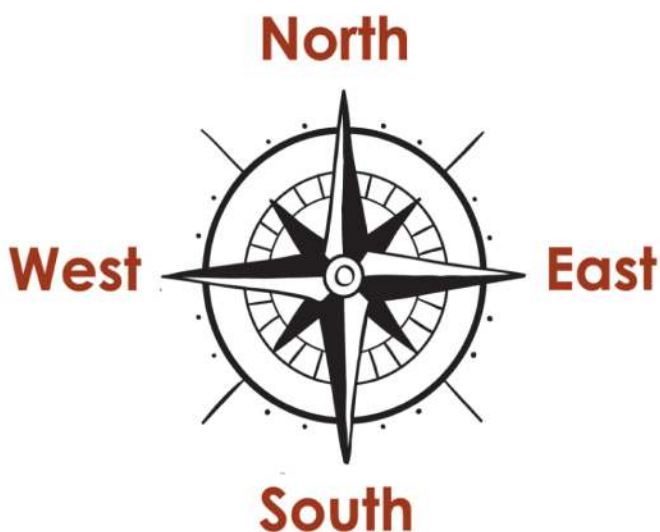



## A TOURIST FOR A DAY

Imagine you are a tourist in town for a day. Write a business you will visit at each time shown on the clocks.

School



Bakery



Restaurant



Souvenir Store



Auto Garage



Hotel



Museum



\_\_\_\_\_

-----

\_\_\_\_\_



\_\_\_\_\_

-----

\_\_\_\_\_



\_\_\_\_\_

-----

\_\_\_\_\_



\_\_\_\_\_

-----

\_\_\_\_\_

HOW THE WORLD WORKS?

CHAPTER 3

# BUYING, SELLING, AND SAVING





## DAILY DIET

Circle the healthy foods we can eat every day.  
Complete the sentence.

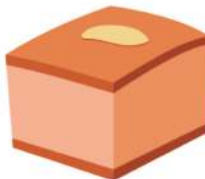

---

---

---

\_\_\_\_\_ foods are healthy foods.



## SHOPPING FOR NADIA

Read the story.

Nadia and her mother are tourists in a new town. When they arrived, Nadia realized she lost a bag on the trip. This morning, they are shopping. These are the goods they still need to buy:

First, they go to the bakery to buy bread. It smells good. Nadia's mother pays the baker 5 LE.

Next, they go to the grocery store to buy honey. Nadia's mother pays the grocer 5 LE.

Next, they go to the pharmacy to buy medicine. Nadia's mother pays the pharmacist 9 LE.

Nadia sees a book of maps she wants at the bookstore. It costs 50 LE. She will save her money so she can buy it next time.



### Grocery List

Bread	toothpaste
Medicine	Honey
Shirt	Book
<del>Toothbrush</del>	<del>Comb</del>



5 LE



5 LE



9 LE

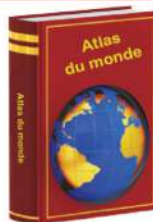





50 LE



## LET'S GO SHOPPING WITH NADIA

Circle the good that costs the most. Draw a triangle around the good that costs the least. Choose two goods to buy. Complete the sentences.

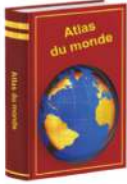
 <p>5 LE</p>	 <p>5 LE</p>	 <p>9 LE</p>
 <p>40 LE</p>	 <p>7 LE</p>	 <p>50 LE</p>

I will buy the \_\_\_\_\_  
 \_\_\_\_\_  
 \_\_\_\_\_

I will buy the \_\_\_\_\_  
 \_\_\_\_\_  
 \_\_\_\_\_

It costs \_\_\_\_\_

It costs \_\_\_\_\_

\_\_\_\_\_ + \_\_\_\_\_ = \_\_\_\_\_

I need \_\_\_\_\_ pounds to buy these goods.

COMMUNICATION

CHAPTER 1

# COMMUNICATING WITH NUMBERS





## MENU NUMBERS

Circle the numbers that communicate price in green. Circle the numbers that communicate time in yellow. Circle the remaining numbers in blue. What information do they communicate?



<p><b>SOUPS</b> (1 bowl ) Lentil Soup – 4 LE Molokhia – 4 LE</p> <p><b>APPETIZERS</b> Mixed Olives – 2 LE Falafel – 4 LE</p>	<p><b>SALADS</b> Green Salad – 5 LE Yogurt Salad – 7 LE</p> <p><b>DRINKS</b> Bottled Water – 3 LE Mowz bil-Laban (banana with milk) – 7 LE</p>
--	--

**The Grill**  
4000 Kasr El Nile - Le Cairo- Egypt  
Hours  
11:00 – 8:00 daily

02-5555-1111



## MISSING NUMBERS

The numbers are missing. Can you help? Use the number bank to put the numbers back where they belong.



NUMBER BANK				
90°C	3:00	30	2 kg	10 LE



## FAVORITE FRUIT

Use the survey information to answer the questions.

The class is going to have fruit for a snack.

The teacher asks the class to choose a favorite fruit.

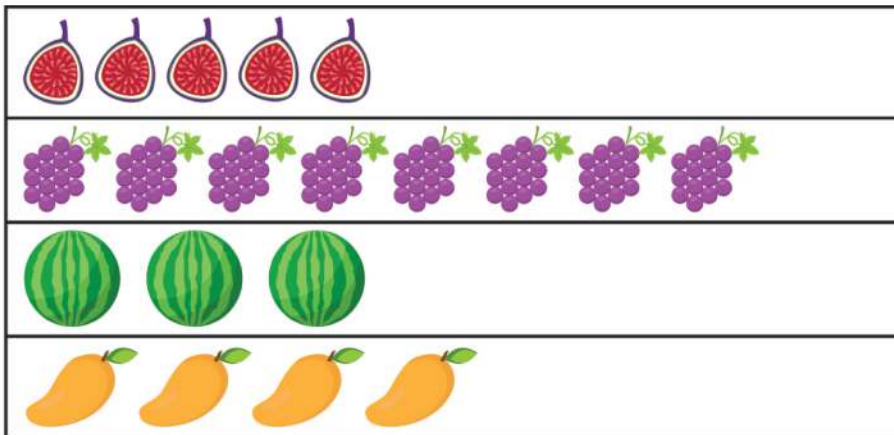

How many students like figs the best? \_\_\_\_\_

How many students like grapes the best? \_\_\_\_\_

How many students like melons the best? \_\_\_\_\_

How many students like mangoes the best? \_\_\_\_\_

Which fruit is the favorite of most students?

\_\_\_\_\_

-----

\_\_\_\_\_

The teacher will buy two kinds of fruit. What should the teacher buy?

\_\_\_\_\_

-----

\_\_\_\_\_



## TECHNOLOGY WITH NUMBERS

Look at the images. Which pictures show technology?

Egyptians used the abacus about 4000 years ago. The abacus is also called a counting frame.



Pascal's Calculator was invented over 300 years ago. It adds and subtracts two numbers. It uses repeated addition and subtraction.



This is an adding machine.  
How does it work?



How is this calculator different from the other examples?



# COMMUNICATING WITH ART





## IMITATING MOVES

Read the words to the song together. Then sing the song together. Write one more verse to the song.



## IF YOU MOVE AND YOU KNOW IT



If you are playing on the playground, spin around.

If you are playing on the playground, spin around.

If you are playing on the playground, spin around really fast.

If you are playing on the playground, spin around.

If you are playing with a ball, kick it high.

If you are playing with a ball, kick it high.

If you are playing with a ball, kick it high into the sky.

If you are playing with a ball, kick it high.

---

---

---



## ART SHOW WEBSITE

Use the website to learn more about the upcoming art show.

Before going to the art show, Habiba searches online for more information. The website says there are photographs, paintings, and sculptures at the art show.



## HABIBA GOES TO THE ART SHOW

Read the story.

**Habiba is happy to go to the art show. Her mother tells her not to touch the art. Habiba nods yes. She knows that the art is special.**

Habiba sees a photograph of the Pyramids of Giza. She would like to visit the pyramids. Habiba thinks about the Ancient Egyptians. She is proud of their accomplishments.

**Habiba sees a painting of flowers. The flowers are tulips. They are different colors. She thinks the flowers are pretty.**

Habiba sees a sculpture of an elephant family. She thinks of her family. They take care of her. She loves her family.

**Habiba had fun at the art show. She is going to go home and be an artist. Will she be a sculptor? A photographer? A painter?**



## BIRD SCULPTURES

Look at the sculptures. These are made from different materials. What materials do you think each is made from?

### WORD BANK

Wood

Paper

Metal

Fabric

Plastic



---



---



---



---



---



---



---



---



---



---



---



---



---



---



---



## MASKS

Look at the masks. Then design your favorite one.





## SHOPPING SCRIPT

Read the buying and selling script together as a class.  
Then, identify and discuss the message being communicated.

**Store worker :** Hello, can I help you?

**Customer :** I am looking for loaves of bread.

**Store worker :** Of course. Let me show you where they are.

**Customer :** How much do the loaves cost?

**Store worker :** They cost 7 LE.

**Customer :** Here is 7 LE.

**Customer hands store worker money for the items.**

**Store worker :** Thank you. Here is your bread.

**Store worker hands the item to customer.**

**Store worker :** Thank you. Here is your bread.

**Customer :** Thank you.

**Store worker :** Nice doing business with you.

**Customer :** You, too. Have a nice day.

**Customer leaves the store.**



تم تحميل هذه الأوراق مجاناً من  
أكبر وأضخم مكتبة تعليمية  
موقع وتطبيق مذكرات جاهزة

## المواصفات الفنية

رقم الكتاب	ورق الغلاف	ورق المتن	طبع الغلاف	طبع المتن	عدد الصفحات بالغلاف	مقاس الكتاب
٢٠/١/٣٣/١٥/٢١/١٠٣٠	٢٠٠ جم	٨٠ جم	٤ لون	٤ لون	٧٦ صفحة	(٢٧×١٩) سم



أولاد كمال فتح الله خضر  
( المصنع الدولي )